

Parts and technical service guide
Guía de servicio técnico y recambio

METALLIC / METÁLICAS

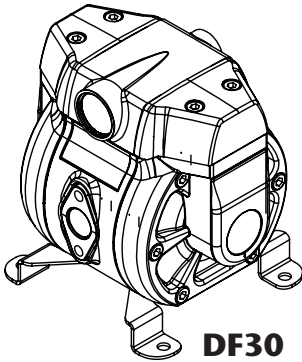

DF30

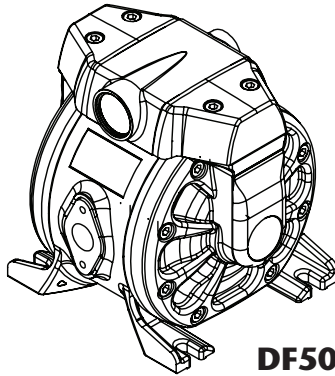

DF50

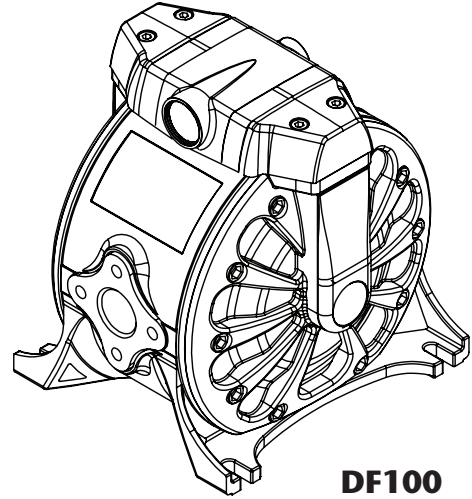

DF100

NON-METALLIC / NO-METÁLICAS

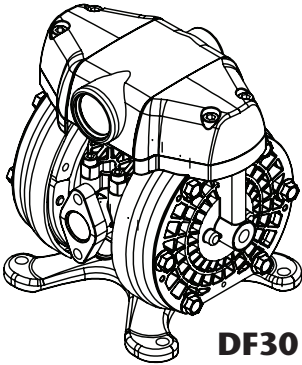

DF30

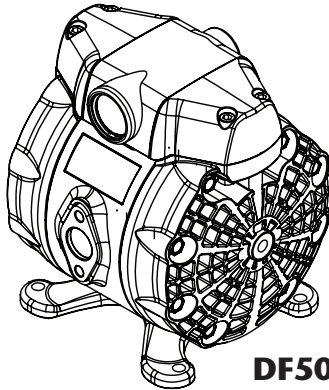

DF50

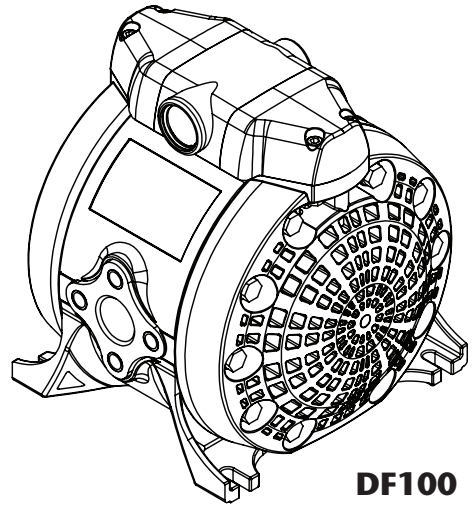

DF100

EN 1/2" DOUBLE DIAPHRAGM PUMP DF30 (38 l/min)
1/2" DOUBLE DIAPHRAGM PUMP DF50 (50 l/min)
1" DOUBLE DIAPHRAGM PUMP DF100 (100 l/min)

4

ES 1/2" BOMBA DE MEMBRANA SERIES DF30 (38 l/min)
1/2" BOMBA DE MEMBRANA SERIES DF50 (50 l/min)
1" BOMBA DE MEMBRANA SERIES DF100 (100 l/min)

16

NOTE: V4.0 Replacement kits valid for previous models.
NOTA: V4.0 Kits de recambio válidos para modelos anteriores.

CAPACITY CURVES / CURVAS DE CAPACIDAD / COURBES DE CAPACITÉ / LEISTUNGSDIAGRAMM

DF30

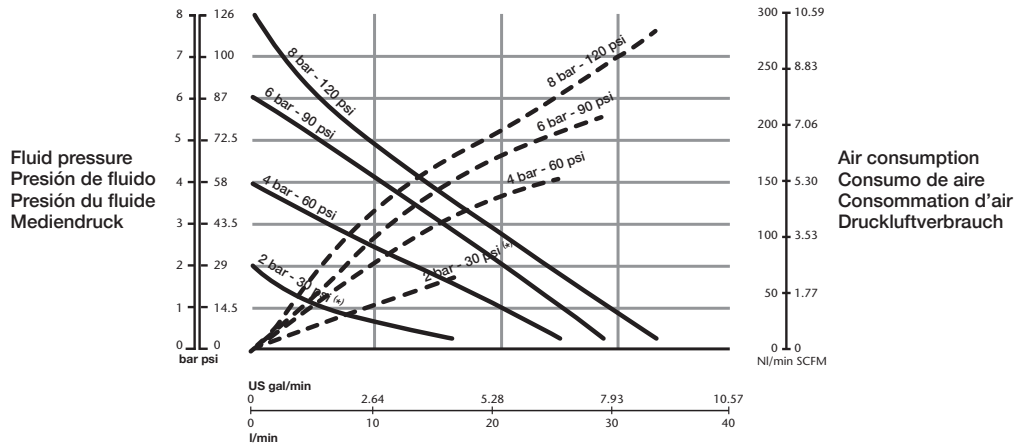

DF50

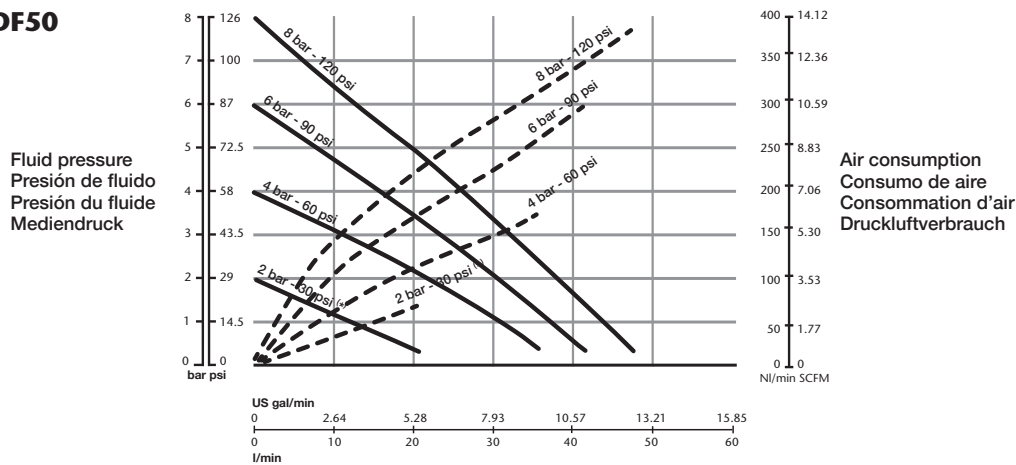

DF100

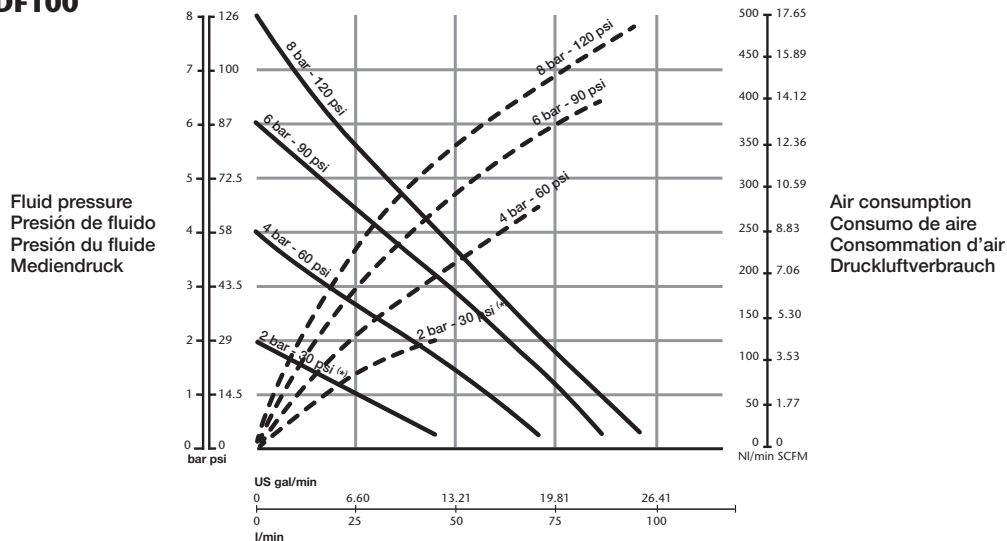

—— OUTLET PRESSURE / SALIDA DE PRESIÓN / PRESSION DE SORTE / AUSGANGSDRUCK
 - - - - AIR CONSUMPTION / CONSUMO DE AIRE / CONSOMMATION D'AIR / DRUCKLUFTVERBRAUCH

(*) 2 bar test with a PTFE (Teflon®) diaphragms pump.
 2 bar testado con bombas de diafragma de PTFE (Teflon®).
 Test à 2 bar de pression, réalisé avec les pompes à membranes PTFE (Teflon®).
 2 bar Test mit einer PTFE-Membranen Pumpe.

DIMENSIONS / DIMENSIONES / DIMENSIONS / LEISTUNGSDIAGRAMM

DF30 / DF30T														
A	B	C	D	E	F	G	H	I	J	K	L	M	N	P
130 mm	160 mm	162 mm	105 mm	122 mm	8 mm	140 mm	135 mm	70 mm	1/2" BSP NPT	145 mm	3/8" BSP NPT	24 mm	M6	41 mm
5.12"	6.3"	6.38"	4.13"	4.8"	0.31"	5.51"	5.31"	2.76"		5.71"	0.94"	0.94"		1.61"

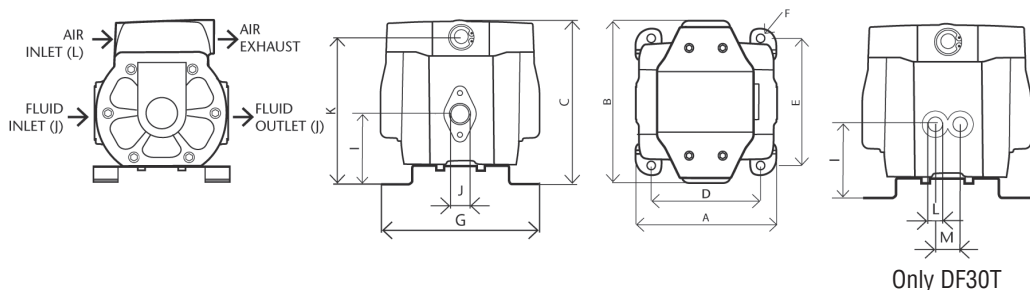

DF50 / DF50T							
A	B	C	D	E	F	G	H
156 mm	160 mm	167 mm	105 mm	122 mm	8 mm	146 mm	140 mm
6.14"	6.3"	6.57"	4.13"	4.8"	0.31"	5.75"	5.51"
H	I	J	K	L	M	N	P
140 mm	70 mm	1/2" BPS NPT NPSM	150 mm	3/8" NPSM	24 mm	M6	41 mm
5.51"	2.76"		5.91"		0.94"		1.61"

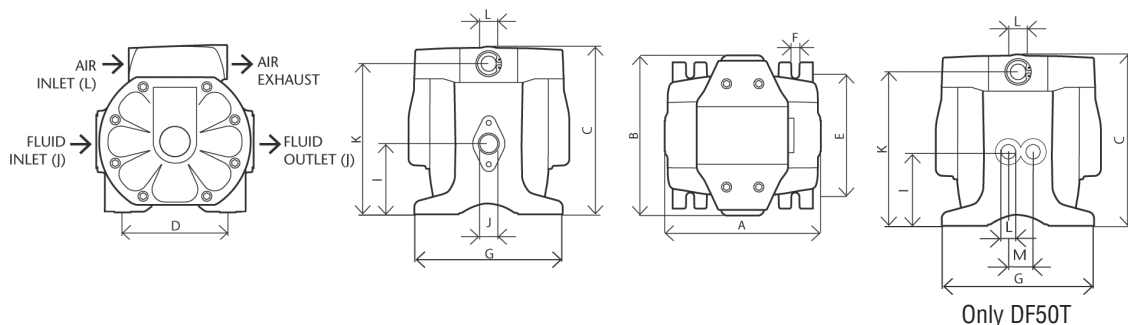

DF100											
A	B	C	D	E	F	G	H	I	J	K	L
216 mm	189 mm	227 mm	175 mm	154 mm	9 mm	184 mm	210 mm	94,51 mm	1" BSP NPT	210 mm	3/8" NPSM
8.5"	7.44"	8.94"	6.89"	6.06"	0.35"	7.24"	8.27"	3.72"		8.27"	

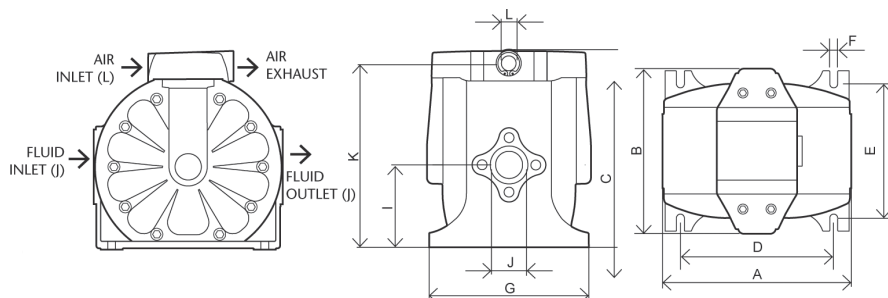

2017_12_04-13:30

TECHNICAL DATA

	DF30	DF50	DF100
RATIO	1:1	1:1	1:1
MAXIMUM FREE FLOW	10 gal/min (38 l/min)	13.21 gal/min (50 l/min)	26.5 gal/min (100 l/min)
DELIVERY PER STROKE	2.37 oz (0,07 l)	3.38 oz (0,1 l)	32 oz (0,25 l)
AIR PRESSURE OPERATING RANGE	22 to 115 psi (1,5 to 8 bar)*	22 to 115 psi (1,5 to 8 bar)*	22 to 115 psi (1,5 to 8 bar)*
SOLID IN SUSPENSION MAX SIZE	0.12 in (3 mm)	0.12 in (3 mm)	0.16 in (4 mm)
MAXIMUM SUCTION HEAD	13.2 ft (4 m) dry, 26.25 ft (8 m) wet	19.69 ft (6 m) dry, 26.25 ft (8 m) wet	14.76 ft (4,5 m) dry, 22.97 ft (7 m) wet
WEIGHT	4.19 lb (1,9 kg)	7.72 lb (3,5 kg) metallic series with aluminium body 4.85 lb (2,2 kg) non metallic series	15.87 lb (7,2 kg) metallic series with Aluminium body 24.69 lb (11,2 kg) metallic series with Stainless steel body 11.24 lb (5,1 kg) non metallic series
FLUID INLET (SINGLE INLET)	1/2" BSP - NPT (F) and flange	1/2" BSP - NPT (F) and flange	1" BSP/NPT (F) and flange
FLUID INLET (DOUBLE INLET)	2 x 3/8" BSP - NPT (F)	2 x 3/8" BSP - NPT (F)	-
FLUID OUTLET	1/2" BSP - NPT (F) and flange	1/2" BSP - NPT (F) and flange	1" BSP/NPT (F) and flange
AIR INLET	3/8" NPSM (F)	3/8" NPSM (F)	3/8" NPSM (F)
WETTED PART MATERIALS	View model specifications	See model specifications	See model specifications
NOISE LEVEL	80 db	80 dB	80 dB
TEMPERATURE RANGE	32 - 158 °F (0 - 70 °C)	32 - 158 °F (0 - 70 °C)	32 - 158 °F (0 - 70 °C)

* For Hytre[®] and Santoprene[®] diaphragms: air pressure between 36 and 115 psi (2,5 bar-8 bar).

(oz, ft, gal/min) all in EEUU units

WARNINGS AND CAUTIONS

In this document you will find warnings and cautions for installation, use and maintenance of the Direcflo pumps.

A continuación le indicamos el significado de los símbolos y mencionamos unas advertencias generales que usted debe tener en cuenta.



WARNING: This symbol aware that there is a danger of serious bodily injury or death if you ignore the warning described.

CAUTION: This symbol aware that there is a danger of personal injury or property damage if you ignore the caution described.



WARNING: ¡CAREFULLY READ THE INSTRUCTIONS AND WARNINGS BEFORE OPERATING THE EQUIPMENT!

- This equipment is for professional use only.
- Do not degrade the integrity of the equipment. Use only original replacement components from Samoa Industrial, S.A.
- Fluids not suitable for the pump can cause damage to the pump unit and involve risk of serious personal injury.
- Always consult Samoa Industrial, S.A. if you have any questions about the compatibility within the fluids and the pump materials, including elastomers.
- Install and use the pump according to all local and national regulations and abide all health and safety laws or legislation.
- The pump can produce fluid pressures equal to the air supply pressure. Do not exceed the maximum allowable pressure of 115 psi (8 bar) air supply. The total hydraulic pressure (differential pressure + system) should never exceed 115 psi (8 bar).
- Never use a pump that leaks, that is damaged, that is corroded or otherwise it may lack the capacity to contain the fluid.
- Frequently check that the bolts on the diaphragm cover of the pump are torqued correctly.
- Do not use a model with aluminium wetted surfaces to pump fluids for human consumption, there is a possibility of trace contamination of lead.
- Danger of explosion if used 1,1,1-trichloroethane, methylene chloride or other halogenated hydrocarbon solvents with aluminium wetted materials. It could cause serious injury and property damage.
- Inside the pump, diaphragms separate the fluid that is being pumped from the air supply. If a diaphragm breaks, the fluid can leak out of the air exhaust and contaminate the environment.
- When handling hazardous fluids, always route the air exhaust into a suitable container and locate it in a safe place.
- When the fluid source level is situated higher than the pump, (flooded suction), the outlet tank must be at a higher level than the product to prevent spills.
- For pumps handling hazardous fluids that are a danger to humans or to the environment, install a suitable container surrounding the pump to prevent any leaks or spills.
- Ensure that the operators of this equipment are trained on the operation and limitations. Use safety equipment as safety goggles or other equipment required.

DESCRIPTION

Air operated double diaphragm pumps are air-powered, reciprocating positive displacement pumps with two pumping chambers. Two diaphragms, centrally located in the chambers, separate the compressed air (dry side) from the fluid being pumped (wet side). A shaft transmits the reciprocating motion of one diaphragm to the other. A directional valve alternatively distributes the air from one chamber to the other; thus a reciprocating movement of the diaphragms is created. With each stroke, fluid is discharged by one of the diaphragms whilst the opposite diaphragm sucks new fluid into the expanding chamber. Check valves, two on the discharge side and two on the suction side, control and direct the fluid flow.

MATERIAL	TEMPERATURE RANGE
PTFE	5 °C - 105 °C / 41 °F - 221 °F
NBR	10 °C - 80 °C / 50 °F - 176 °F
Acetal	10 °C - 90 °C / 50 °F - 194 °F
Hytre [®]	10 °C - 90 °C / 50 °F - 194 °F
Neoprene [®]	-18 °C - 93 °C / 0 °F - 200 °F
Santoprene [®]	-29 °C - 135 °C / -20 °F - 275 °F
Polypropylene [®]	10 °C - 80 °C / 50 °F - 176 °F

INSTALLATION

INSTALLATION RECOMMENDATIONS

- Remove the pump from its package and install it on the chosen location.
- Try to minimize the suction head. Install the pump as close as possible to the fluid being pumped.
- Remember to have enough space around the pump to perform maintenance tasks.
- Keep in mind to connect the inlet and outlet of the pump correctly.
- In case of diaphragm pump failure, the air exhaust will expell the product being pumped.
- When the pump is installed in a place where a spill of fluid can cause an environmental impact, the exhaust should be directed to a place where the spill could be contained.
- When installing the pump in its place, use brackets to secure its base.
- Fasten all bolts with the torques contained in this manual.

DF pumps are very easily configured and easy to install.

FLOODED:

The pumping system was designed with positive pressure at the inlet. This is the best possible installation when you need to evacuate the liquid from the drum or tank, or when working with viscous fluids.

Not recommended for hazardous fluids.

SELF-PRIMING:

Pump is designed to generate vacuum. It is possible to evacuate all the air from a hose or pipe without damaging the pump. Maximum suction height is 19.69 ft (6 m), with the suction hose empty and up to 26.25 ft (8 m) with the hose primed. (See page 4 for corresponds suction lift).

SUBMERGED:

All pumps can be immersed in fluids. It is important to verify that all components that are in contact with the fluid are chemically compatible. In this case, air exhaust and fluid must be carried by hoses (optional air connection).

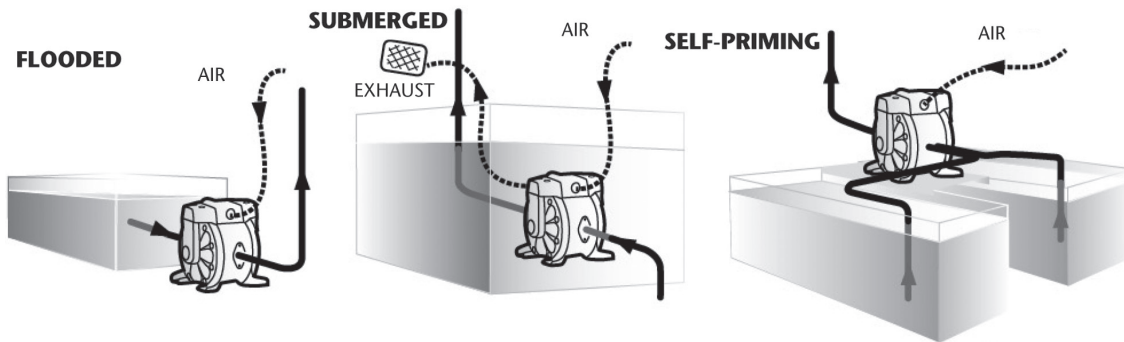

NOTE: Use a pressure regulator with built-in filter inlet.

NOTE: The compressed air supply must be between 22 psi (1,5 bar) and 115 psi (8 bar), Hytrel® and Santoprene® between 36 and 115 psi (2,5 and 8 bar).

RECOMMENDED INSTALLATION

The figure below shows the recommended configuration for the installation of a diaphragm pump. Read the warnings and recommendations of the previous page before starting.

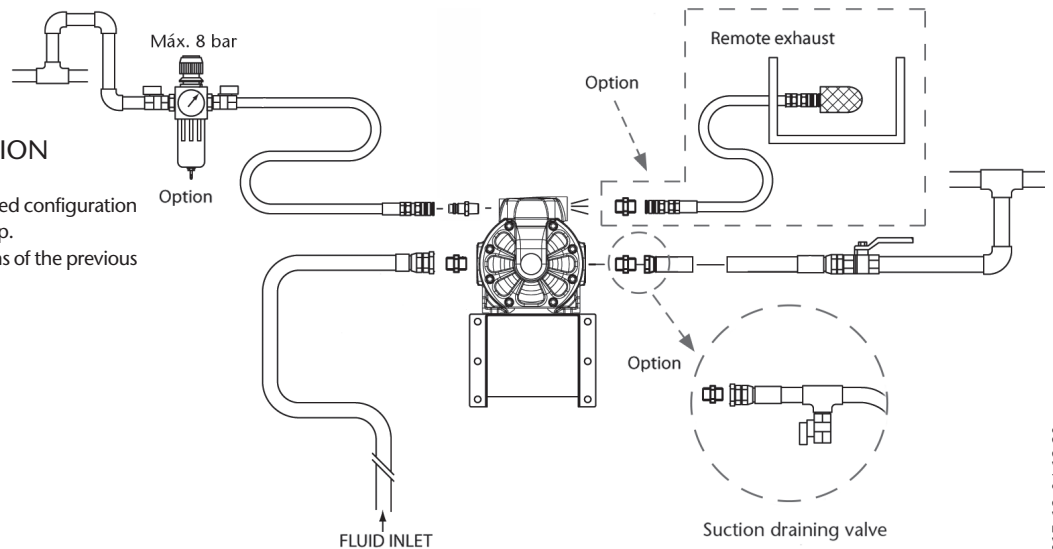

AIR EXHAUST DISPOSAL

WARNING: The pump exhaust should be directed to a safe place, away from people, animals and food.

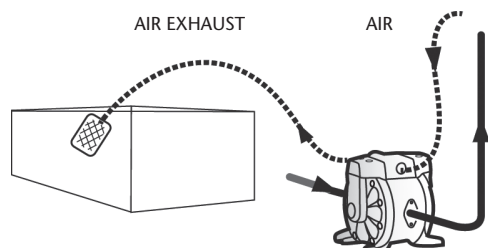

- Optional kit is required for remote exhaust.
- Remove the muffer.
- Connect a hose to the exhaust port of the pump and install the muffer at the end of the hose. Use a hose with the same diameter as the exhaust port. (If the hose is more than 5 feet (1.5 m), consult your dealer or Samoa Industrial, S.A.).
- Have a moat, a protective housing, etc. at the end of the hose.

2017_12_04-13:30

INSTALLATION



WARNING

AIR CONNECTION

To ensure that the air supply is sufficient to meet the demand of the pump, the diameter of the pipe must be equal to the diameter of the supply port of the pump. Choose auxiliary air treatment equipment and fittings with sufficient airflow to exceed the air consumption of the pump. In addition,

peripheral air treatment equipment must be installed as close as possible to the pump unit.

The use of a coupler to connect the hoses aids future operation and maintenance tasks.

OPERATING INSTRUCTIONS

This pump is self-priming.

To prime it the first time, you must connect the air pump supply to a low pressure using the pressure regulators while keeping the outlet valve open. When fluid begins to flow from the pump outlet, the pump is primed. For regulation of fluid pressure, the unit must be supplied with an air pressure between 22 and 115 psi (1,5 and 8 bar), Hytre[®] and Santoprene[®] between 36 and 115 psi (2,5 and 8 bar). Adjust the discharge valve on the discharge side to control flow. For the performance characteristics of the pump see the capacity curve shown on page 6.

STOPPING THE PUMP

- Close the inlet valve of the pump.
- Open the air valve of the pump, turn on the pump and flush the remaining fluid.
- Close the discharge valve on the discharge side, then begin to slowly open the drain valve and discharge pressure fluid.
- After ensuring that the pump was turned off and the pressure was released, fully open and close the regulator valve and drain valve of the pump.

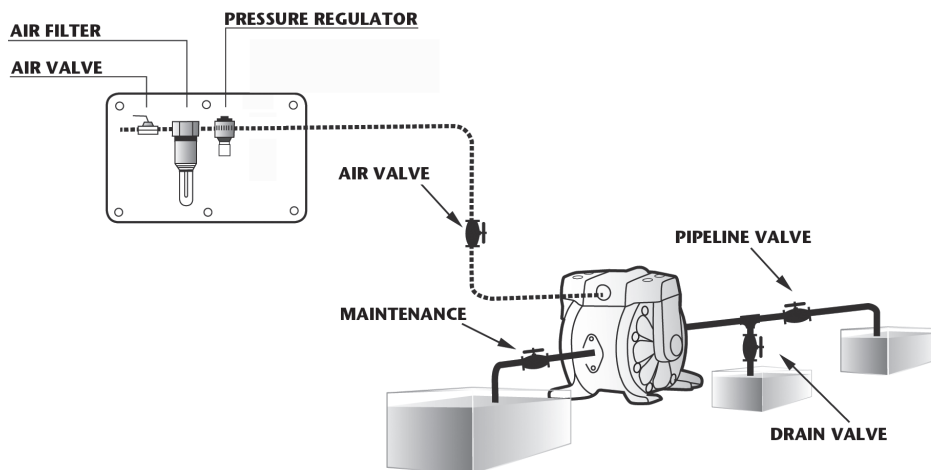

GROUNDING THE PUMP

- When installing the pump, be sure to perform grounding in the specified location.
- Also connect ground wires for the auxiliary equipment and piping.
- Use a grounding cable of at least 12 gauge (2.0 mm²).

- If the pump you have purchased is valid for Atex, a specific Atex manual will accompany this one. Read this manual before operating the pump.

- If the unit is marked with the symbol,  it can be used in potentially explosive atmospheres. Below this symbol, in the nameplate of the pump, are indicated the areas for which the equipment is approved. You will also find the maximum allowable surface temperature in the same plate.

STICKER THAT SHOWS THE POSITION OF THE GROUND WIRE

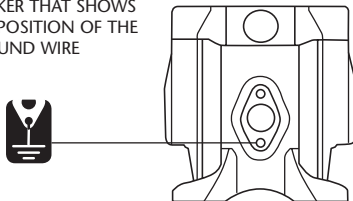

directflo [®]		PATENTED WORLDWIDE	
PUMP TYPE:		CE	EAC
PART No.:		0163	
YEAR:	SERIAL No.:	112 GD	118/11C 95°C
MAX. AIR / FLUID PRESSURE:		LOM 10ATEX105X	
FLUID IN / OUT:			



WARNING: Connect grounding wires to the pump, piping and all other equipment too.

When the pump operates ungrounded or with an incorrect connection, friction between parts and abrasion caused by some fluids that flow inside the pump, can generate static electricity. Moreover, according to the type of fluid pump and the installation environment (such as gases in the air or the type of the surrounding facilities) static electricity can cause fire or electric shock.

TROUBLESHOOTING

THE PUMP DOES NOT WORK	
Cause	Recommended measure
The discharge valve on the discharge side is not open.	Open the discharge valve on the discharge side.
No air supply.	Turn on the compressor and open the air valve and air regulator.
The air supply pressure is low.	Check the compressor and the configuration of the air line. Adjust the air pressure.
Air leaks in connecting elements.	Check the connection elements and the tightening of the screws.
The air pipes or ancillary equipment is clogged with mud.	Check and clean the air line.
The exhaust port (muffler) of the pump is clogged with mud.	Check and clean the exhaust port and muffler. Replace if necessary.
The fluid pipe is clogged with mud.	Check and clean the fluid line.
Pump is clogged with mud.	Remove, inspect and clean the pump body.

THE PUMP RUNS BUT NO FLUID COMES OUT	
Cause	Recommended measure
The valve on the suction side is not open.	Open the valve on the suction side.
Too much suction or discharge height.	Confirm the configuration of the pipe and reduce the height of the same.
Fluid pipe discharge side (including the filter) is clogged with mud.	Check and clean the fluid line.
Pump is clogged with mud.	Dismantle the pump, check and clean.
The ball and ball seat is worn or damaged.	Inspect and replace parts.

THE FLOW IS DECREASING	
Cause	Recommended measure
The air supply pressure is low.	Check the compressor and the configuration of the air line. Adjust the air pressure.
The air line or peripheral equipment clogged with mud.	Check and clean the air line.
Valve discharge side drive will not open normally.	Adjust the discharge valve discharge side.
The air mixes with the fluid.	Replenish fluid and check the configuration of the pipe on the suction side.
Cavitation occurs.	Adjust air supply pressure and discharge pressure and reduce the suction.
Vibrations.	Adjust air supply pressure and discharge pressure. Reduce the flow of the inlet valve to adjust pressure and volume of fluid.
Ice formation in the air exhaust.	Remove ice from the air bypass valve and check and clean the air filter. Use a pipe in the exhaust air that the ice does not form in the muffler.
The fluid line (including the filter) plugged with mud.	Check and clean the fluid pipe and strainer.
The exhaust port (muffler) of the pump is clogged with mud.	Check and clean the exhaust port and muffler. Replace if necessary.
Pump is clogged with mud.	Remove, inspect and clean the pump body.

LEAKAGE OF FLUID THROUGH THE HOLLOW EXHAUST (SILENCER)	
Cause	Recommended measure
The diaphragm is damaged.	Remove and inspect the pump and replace the diaphragm.

POWERED AIR LEAK PRESSURE OF 3 TO 8 BAR	
Cause	Recommended measure
Wear directional valve.	Replace directional valve components.

IRREGULAR VIBRATION	
Cause	Recommended measure
The air supply pressure is too high.	Adjust air supply pressure.
The pump is clogged with particles larger than the diameter allowed.	Remove, check and clean the pump body.
The elements of connection and the support of the pump are loose.	Review each element of connection and tighten the screws.

IN FLUID WITH AIR BUBBLES	
Cause	Recommended measure
Diaphragm damaged.	Replace diaphragm.
Suction hose loose or broken.	Tighten or replace.

NO START-UP AND IS LEAKING AIR WITHOUT CYCLES	
Cause	Recommended measure
Stiff air sensors.	Change air sensor.
Wear directional valve.	Replace.

2017_12_04-13:30

DF30 BODY PUMP PARTS

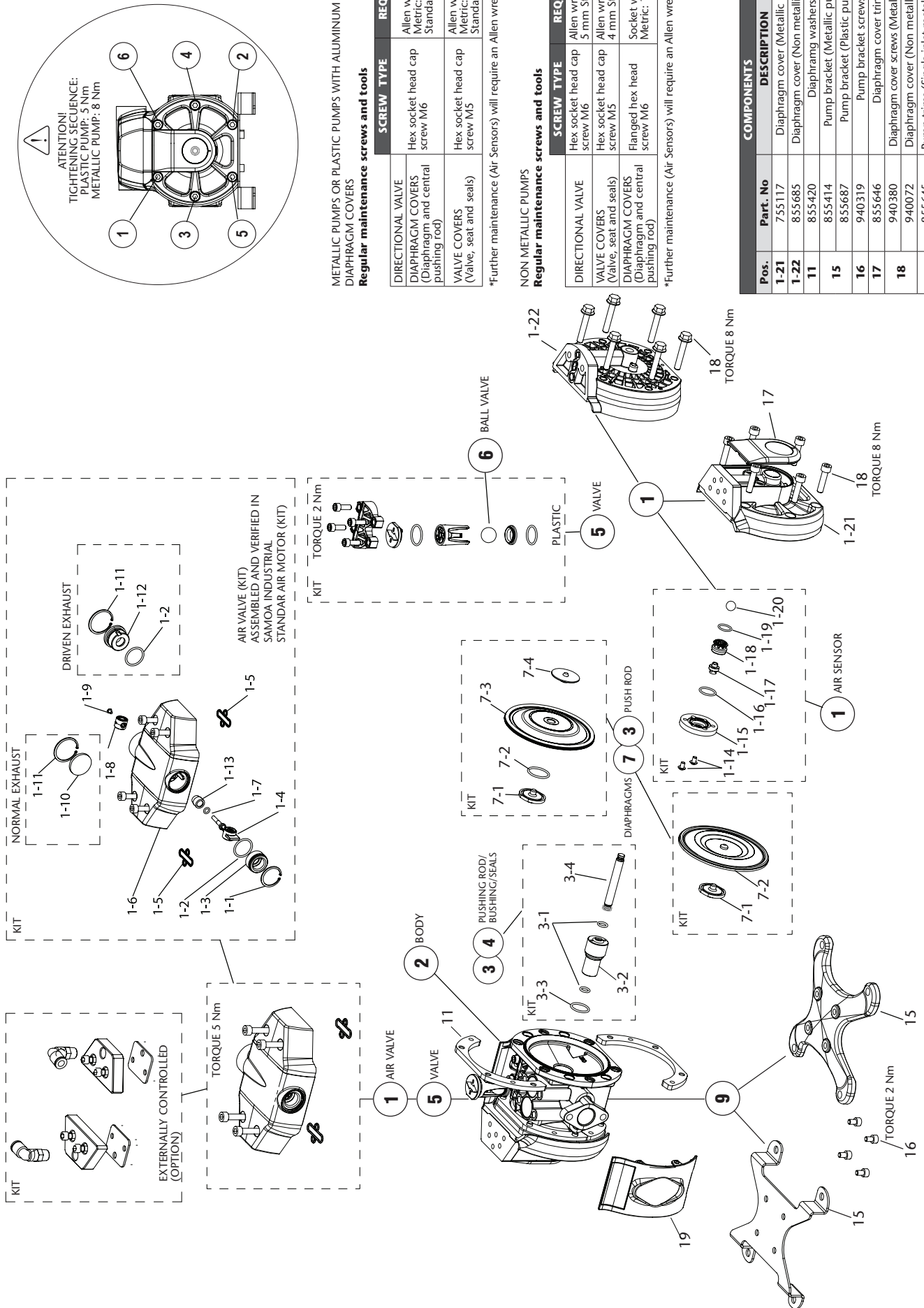

METALLIC PUMPS OR PLASTIC PUMPS WITH ALUMINIUM DIAPHRAGM COVERS

Regular maintenance screws and tools

DIRECTIONAL VALVE DIAPHRAGM COVERS (Diaphragm and central pushing rod)	SCREW TYPE	REQUIRED TOOL
HEX SOCKET HEAD CAP SCREW M6	HEX SOCKET HEAD CAP SCREW M6	Allen wrench Metric: 5 mm Standard: 3/16"
HEX SOCKET HEAD CAP SCREW M5	HEX SOCKET HEAD CAP SCREW M5	Allen wrench Metric: 4 mm Standard: 5/32"

*Further maintenance (Air Sensors) will require an Allen wrench: Metric 3 mm

NON METALLIC PUMPS

Regular maintenance screws and tools

DIRECTIONAL VALVE	SCREW TYPE	REQUIRED TOOL
HEX SOCKET HEAD CAP SCREW M6	HEX SOCKET HEAD CAP SCREW M6	Allen wrench Metric: 5 mm Standard: 3/16"
HEX SOCKET HEAD CAP SCREW M5	HEX SOCKET HEAD CAP SCREW M5	Allen wrench Metric: 4 mm Standard: 5/32"
FLANGED HEX HEAD SCREW M6	FLANGED HEX HEAD SCREW M6	Socket wrench Metric: 10 mm

*Further maintenance (Air Sensors) will require an Allen wrench: Metric 3 mm

Pos.	Part. No	DESCRIPTION	Cant
1-21	755117	Diaphragm cover (Metallic pumps)	2
1-22	855685	Diaphragm cover (Non metallic pumps)	2
11	855420	Diaphragm washers	4
15	855414	Pump bracket (Metallic pumps)	1
	855687	Pump bracket (Plastic pumps)	1
16	940319	Pump bracket screws	4
17	855646	Diaphragm cover trim	2
18	940380	Diaphragm cover screws (Metallic pumps)	12
	940072	Diaphragm cover (Non metallic pumps)	12
19	855645	Pump trims (Single inlet metallic pumps)	2
	855645+855670	Pump trims (Double inlet metallic pumps)	1+1

DF30	X	X	X	X	X	X	X	X	X	X	X	X
	1	2	3	4	5	6	7	8	9			
AIR VALVE	BODY PUMP	PUSH ROD	SEALS	SEATS	BALLS	DIAPHRAGMS	CONNECTIONS	OPTIONS				
A Aluminum P Polypropylene	B Conductive PP D Conductive POM W PVDF K Conductive PVDF	S Stainless steel Y Hastelloy® C	N NBR V FKM E EPDM T PTFE	S Stainless steel W PVDF	T PTFE C POM S Stainless steel N NBR	H Hytrel® T PTFE M Santoprene® N NBR	B BSP N NPT F Flange	A Standard pump B Remote exhaust kit included E Externally controlled with solenoid valve (not included) F Nose muffler included G Externally controlled with solenoid valve (not included) and inductive end of stroke sensors NPN (included) I Externally controlled with solenoid valve (not included) and inductive end of stroke sensors ATEX-Namur (included) U Pump suitable for UV fluids				

1			AIR VALVE		
AIR VALVE	AIR SENSORS	REMOTE EXHAUST			
A 558300	558301	-			
P 558343		-			

2						PUMP BODY					
						PART. No					
SIMPLE			DOUBLE								
BSP	NPT	BSP	NPT	BSP	NPT						
B 855661	855661.300	-	-	-	-						
D 855660	855660.300	-	-	-	-						
P 855644	855644.300	855669	-	-	-	855669.300					
W 855676	855676.300	-	-	-	-	-					
K 855677	855677.300	-	-	-	-	-					

3			4			PUSH ROD REPAIR KIT		
PUSH ROD	SEALS	KIT CODE						
S	N	558325.001						
S	V	558326.001	553010, 553020, 553124, 553160, 553162, 553164					
S	E	558328.001				553161		
S	T	558431.001				-		
Y	V	558427.001				-		
Y	T	558425.001				-		

NOTE: For Serial numbers prior to 329041/250 the replacement kit has to be ordered without .001 suffix.

6			CHECK VALVE BALL REPAIR KIT		
BALLS	KIT CODE	NUMERICAL CODING 55xxxx			
T	558319	553010, 553020, 553124, 553160, 553161, 553162, 553164			
C	558321	-			
S	558342	-			
N	558320	-			

2			4			5			VALVE REPAIR KIT		
PUMP BODY	SEALS	SEATS	CÓD. KIT	NUMERICAL CODING 55XXXX							
P	V	S	558316.001	553010, 553020, 553124, 553160, 553164							
P	E	S	558336.001	553161							
P	T	S	558349.001								
P	V	W	558318.001								
P	T	W	558407.001								
D	V	S	558417.001								
D	E	S	558418.001								
D	T	S	558419.001								
B	V	S	558410.001								
B	E	S	558411.001								
B	T	S	558412.001								
K, W	T	W	558346.001								

7			DIAPHRAGMS		
DIAPHRAGMS	PUSH ROD	KIT CODE	NUMERICAL CODING 55xxxx		
H	S	558337.001	553010, 553020, 553124, 553164		
M	S	558343.001	-		
N	S	-	-		
T	S	558344.001	553160, 553161, 553162		
T	Y	558345.001	-		

MODEL EXAMPLE

directflo PATENTED WORLDWIDE

PUMP TYPE: _____

PART No.: _____

YEAR: _____

MAX. AIR / FLUID PRESSURE: _____

FLUID IN / OUT: _____

CE EAC

0183

112 GPa

118/11C 95°C

LOW TORQUE/ROSK

Part. No: 55XXXX (numerical coding)
 Pump type: DF30XXXXXXX (alphanumeric coding)

DF50 BODY PUMP PARTS

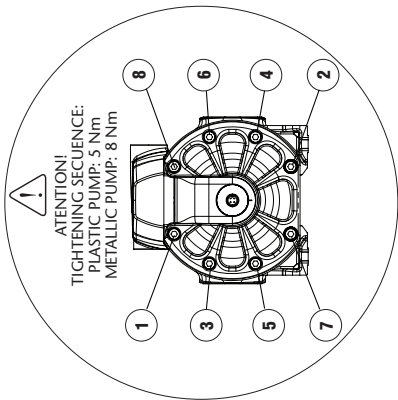

METALLIC PUMPS OR PLASTIC PUMPS WITH ALUMINIUM DIAPHRAGM COVERS

Regular maintenance screws and tools

SCREW TYPE	REQUIRED TOOL
DIRECTIONAL VALVE Hex socket head cap screw M6 (Diaphragm and central pushing rod)	Allen wrench Metric: 5 mm Standard: 3/16"
VALVE COVERS (Valve, seat and seals)	Allen wrench Metric: 4 mm Standard: 5/32"

*Further maintenance (Air Sensors) will require an Allen wrench: Metric 3 mm

NON METALLIC PUMPS

Regular maintenance screws and tools

SCREW TYPE	REQUIRED TOOL
DIRECTIONAL VALVE Hex socket head cap screw M6	Allen wrench Metric: 5 mm Standard: 3/16"
VALVE COVERS (Valve, seat and seals)	Allen wrench Metric: 4 mm Standard: 5/32"
DIAPHRAGM COVERS (Diaphragm and central pushing rod)	Socket wrench Metric: 10 mm

*Further maintenance (Air Sensors) will require an Allen wrench: Metric 3 mm

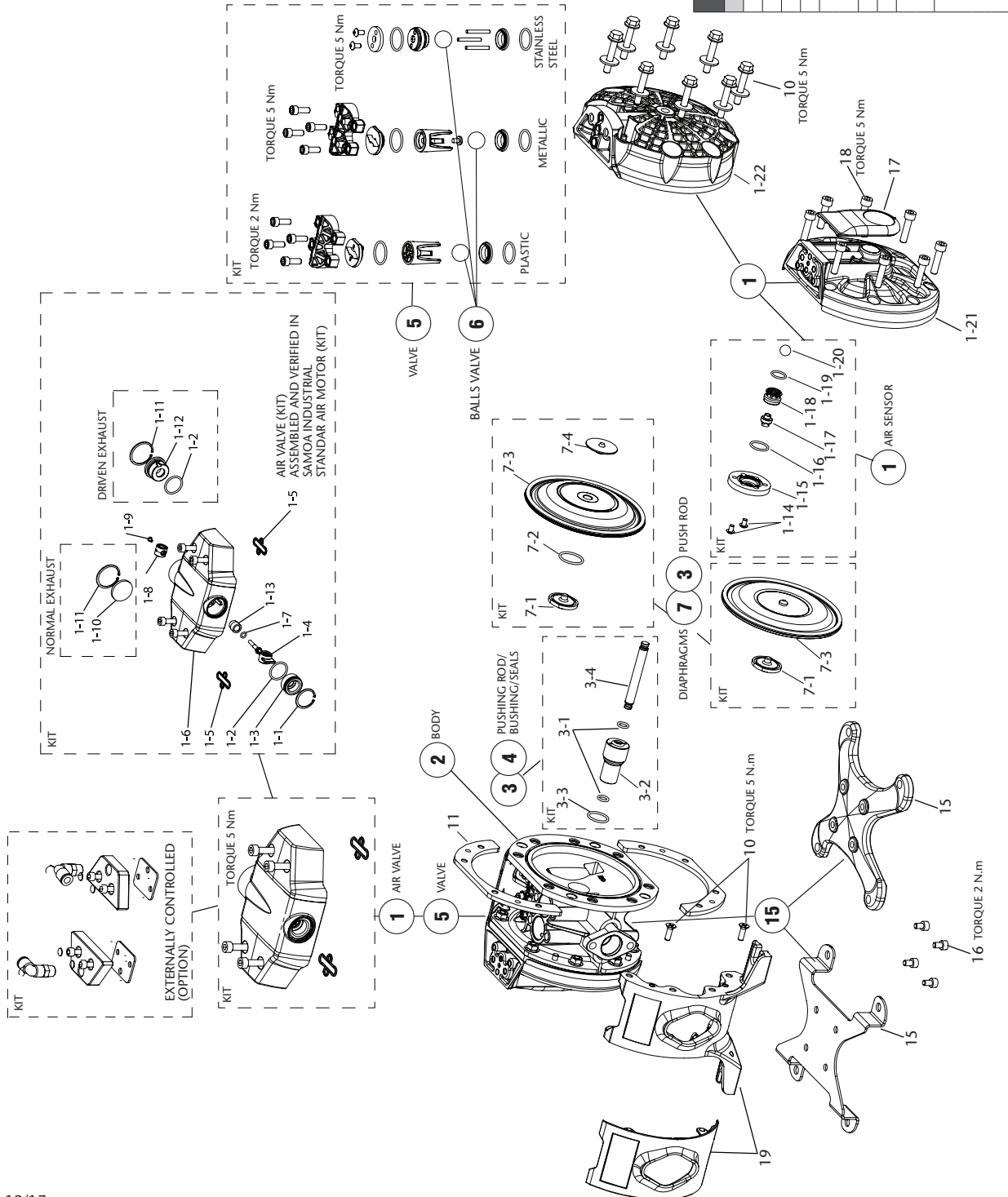

COMPONENTS			
POS.	Part. No	DESCRIPTION	CANT
1-21	755106	Diaphragm cover (Metallic pumps)	2
1-22	894622	Diaphragm cover (Plastic pumps)	16
10	940506	Fixing bolt (metallic pump shield)	8
11	855413	Diaphragm washers	4
15	855414	Pump bracket (Metallic pumps)	1
16	855687	Pump bracket (Plastic pumps)	1
17	940319	Pump bracket screws	4
18	855601	Diaphragm cover trim	2
18	940380	Diaphragm cover screws (Metallic pumps)	16
18	940072+942156	Diaphragm cover (Non metallic pumps)	16+16
19	755108	Pump trims (Single inlet metallic pumps)	2
19	755108+755109	Pump trims (Double inlet metallic pumps)	1+1
19	855625	Pump trims (Single inlet plastic pumps)	2
19	855625+855626	Pump trims (Double inlet plastic pumps)	1+1

DF50	X	X	X	X	X	X	X	X	X	X	X	X
	1	2	3	4	5	6	7	8	9			
	AIR VALVE	BODY PUMP	PUSH ROD	SEALS	SEATS	BALLS	DIAPHRAGMS	CONNECTIONS	OPTIONS			
	A Aluminum P Polypropylene	A Aluminum S Stainless steel P Polypropylene B Conductive PP C POM D Conductive POM W PVDF K Conductive PVDF	S Stainless steel Y Hastelloy® C	N NBR V FKM E EPDM T PTFE	S Stainless steel W PVDF	T PTFE C POM S Stainless steel N NBR	H Hytrel® T PTFE M Santoprene® N NBR	B BSP N NPT F Flange	A Standard pump B Remote exhaust kit included E Externally controlled with solenoid valve (not included) F Nose muffler included G Externally controlled with solenoid valve (not included) and inductive end of stroke sensors NPN (included) I Externally controlled with solenoid valve (not included) and inductive end of stroke sensors ATEX-Namur (included) U Pump suitable for UV fluids			

3	PUSH ROD		PUSH ROD REPAIR KIT	
	SEALS	KIT CODE	NUMERICAL CODING 55XXXX	
S	N	558304.001	552010, 552030	
S	V	558307.001	552015, 552016, 552017, 552018, 552025, 552026, 552124, 552160, 552162, 552164	
S	E	558333.001	552161	
S	T	558432.001	552013, 552014, 552023, 552024, 552050	
Y	V	558312.001		
Y	T	558426.001		

NOTE: For Serial numbers prior to 329041/250 the replacement kit has to be ordered without .001 suffix.

6	CHECK VALVE BALL REPAIR KIT	
	KIT CODE	NUMERICAL CODING 55XXXX
T	558319	552012, 552013, 552014, 552015, 552017, 552022, 552023, 552024, 552025, 552050, 552124, 552160, 552161, 552162, 552164, 552010, 552011, 552016, 552018, 552021, 552026,
C	558321	-
S	558342	-
N	558320	552030

7	DIAPHRAGMS		
	PUSH ROD	KIT CODE	NUMERICAL CODING 55XXXX
H	S	558303.001	552010, 552011, 552015, 552016, 552018, 552021, 552025, 552026, 552124, 552164
M	S	558306.001	-
N	S	558430.001	552030
T	S	558309.001	552012, 552013, 552014, 552017, 552022, 552023, 552024, 552050, 552160, 552161, 552162
T	Y	558347.001	-

MODEL EXAMPLE

directflo PATENTED WORLDWIDE

CE
UL
112 60
118/116 95°C
1.0M TORQUE/RSK

PUMP TYPE: _____
PART No.: _____
YEAR: _____ SERIAL No.: _____
MAX. AIR / FLUID PRESSURE: _____
FLUID IN / OUT: _____

Part. No: 55XXXX (numerical coding)
Pump type: DF50XXXXXXX (alphanumeric coding)

1	AIR VALVE		REMOTE EXHAUST	
A	558300			
P	558543	558301		

2	BODY PUMP			
	SIMPLE	NPT	BSP	DOUBLE
A	755104	755104.300	755105	755105.300
B	855649	855649.300	-	-
C	855618	855618.300	855619	855619.300
D	855628	855628.300	-	-
P	855607	855607.300	855608	855608.300
S	855050	855050.300	-	-
W	855692	855692.300	-	-
K	855697	855697.300	-	-

2	VALVE REPAIR KIT		NUMERICAL CODING 55XXXX
	SEALS	CÓD. KIT	
C	N	558314.001	-
C	N	558429.001	552010, 552030
C	V	558315.001	552014, 552016, 552024, 552026
C	E	558334.001	-
C	T	558403.001	-
C	V	558428.001	-
P	N	558408.001	-
P	S	558316.001	552013, 552015, 552023, 552025, 552124, 552160, 552164, 552161
P	E	558336.001	-
P	T	558349.001	-
P	W	558318.001	-
P	T	558407.001	-
D	V	558417.001	552017, 552010
D	E	558418.001	-
D	T	558419.001	-
B	V	558410.001	552162
B	E	558411.001	-
B	T	558412.001	-
K, W	T	558346.001	-
S	T	558341 - 558341.001	552050 ASK SAMOA
A	N	558421.001	-
A	V	558422.001	-
A	E	558423.001	-
A	T	558424.001	-

2017_12_04-13:30

DF100 BODY PUMP PARTS

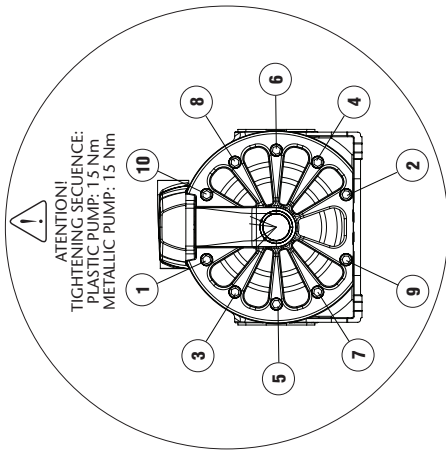

⚠️ ATTENTION!
TIGHTENING SEQUENCE:
PLASTIC PUMP: 15 Nm
METALLIC PUMP: 15 Nm

METALLIC PUMPS OR PLASTIC PUMPS WITH ALUMINIUM DIAPHRAGM COVERS
Regular maintenance screws and tools

	SCREW TYPE	REQUIRED TOOL
DIRECTIONAL VALVE	Hex socket head cap screw M6	Allen wrench Metric: 5 mm Standard: 3/16"
DIAPHRAGM COVERS (Diaphragm and central pushing rod)	Hex socket head cap screw M8	Allen wrench Metric: 6 mm Standard: N/A.
VALVE COVERS (Valve, seat and seals)	Hex socket head cap screw M5	Allen wrench Metric: 4 mm Standard: 5/32"

*Further maintenance (Air Sensors) will require an Allen wrench: Metric 3 mm

NON METALLIC PUMPS

Regular maintenance screws and tools

	SCREW TYPE	REQUIRED TOOL
DIRECTIONAL VALVE	Hex socket head cap screw M6	Allen wrench Metric: 5 mm Standard: 3/16"
VALVE COVERS (Valve, seat and seals)	Hex socket head cap screw M5	Allen wrench Metric: 4 mm Standard: 5/32"
DIAPHRAGM COVERS (Diaphragm and central pushing rod)	Flanged hex head screw M8	Socket wrench Metric: 13 mm Standard: 1/2"

*Further maintenance (Air Sensors) will require an Allen wrench: Metric 3 mm

COMPONENTS

Pos.	Cód	Descripción	Cant
1-21	755111	Diaphragm cover (Metallic pumps)	2
1-22	894621	Diaphragm cover (Plastic pumps)	2
11	855416	Diaphragm washers	4
15	755114	Pump bracket (Metallic pumps)	1
16	855637	Pump bracket (Plastic pumps)	1
17	940914	Pump bracket screws	7
17	855604	Diaphragm cover trim	2
18	940334	Diaphragm cover screws (Metallic pumps)	20
18	940086+942158	Diaphragm cover screws (Plastic pumps)	20+20
19	755113	Pump trims (Single inlet pumps)	1
19	855636	Pump trims (Double inlet pumps)	1

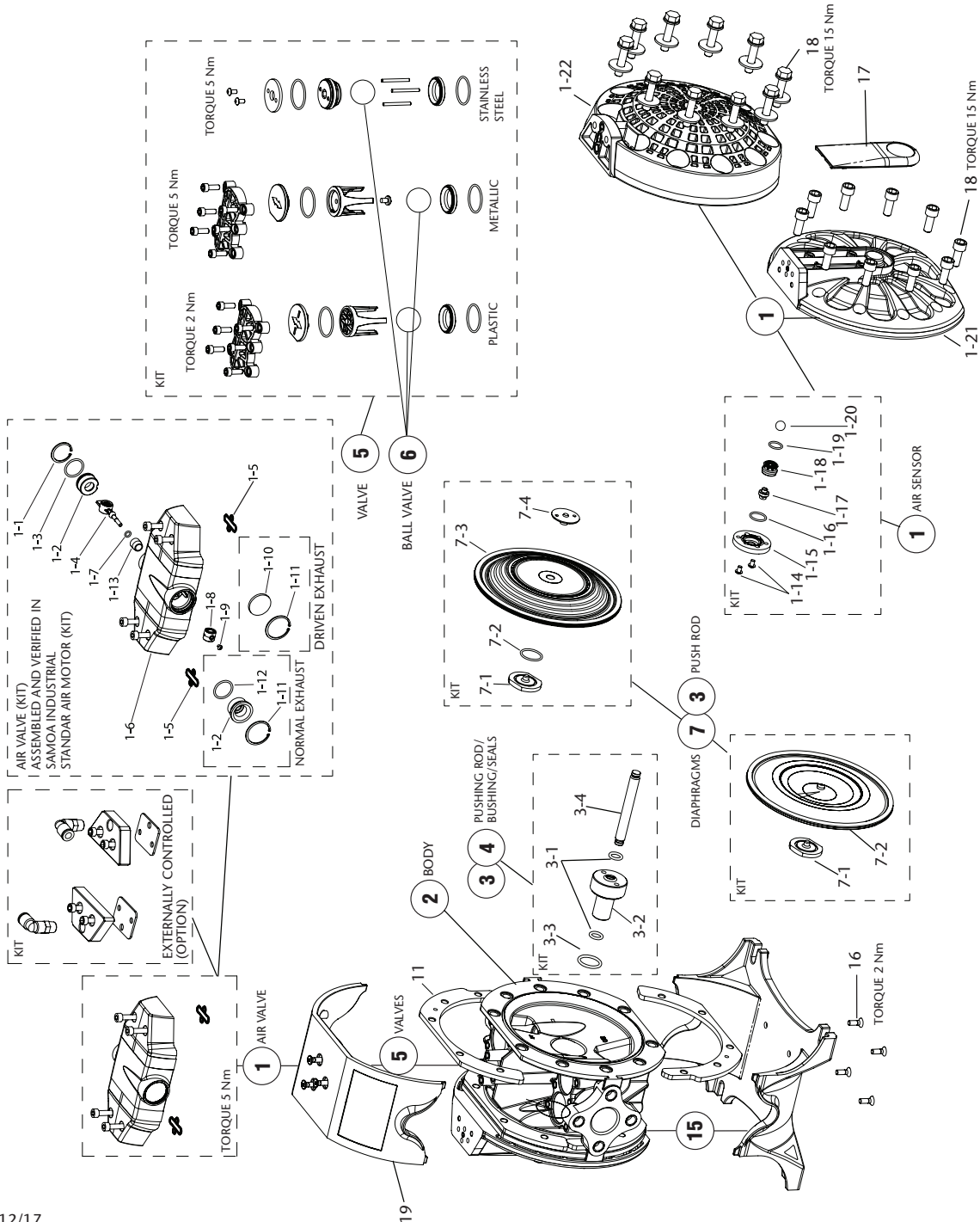

DF100	X	X	X	X	X	X	X	X	X	X	X	X	X
1	2	3	4	5	6	7	8	9					
AIR VALVE	BODY PUMP	PUSH ROD	SEALS	SEATS	BALLS	DIAPHRAGMS	CONECTIONS	OPTIONS					
A Aluminum P Polypropylene	A Aluminum S Stainless steel P Polypropylene B Conductive PP D Conductive POM W PVDF K Conductive PVDF	S Stainless steel Y Hastelloy® C	N NBR V FKM E EPDM T PTFE	S Stainless steel W PVDF	T PTFE C POM S Stainless steel N NBR	H Hytrel® T PTFE M Santoprene® N NBR	B BSP N NPT F Flange	A Standard pump B Remote exhaust kit included D Cycle sensor E Externally controlled with solenoid valve (not included) F Nose muffler included G Externally controlled with solenoid valve (not included) and inductive end of stroke sensors NPN (included) I Externally controlled with solenoid valve (not included) and inductive end of stroke sensors ATEX-Namur (included) U Pump suitable for UV fluids					

1		AIR VALVE	
A	AIR VALVE	AIR SENSORS	
B	558350	558301	REMOTE EXHAUST
	558395		

2		PUMP BODY	
A	BSP	NPT	
B	755110.300	855651.300	
D	855632.300	855630.300	
P	855630.300	855051.300	
S	855051.300	894623.300	
W	894623.300	855698.300	
K	855698.300		

2		4		5	
PUMP BODY	SEALS	SEATS	KIT CODE	NUMERICAL CODING	55XXXXX
P	N	S	558463.001	-	
P	V	S	558360.001	551015, 551160, 551164	
P	E	S	558393.001	-	
P	T	S	558450.001	-	
P	V	W	558362.001	-	
P	T	W	558454.001	-	
D	N	S	558357.001	551017	
D	V	S	558359.001	-	
D	E	S	558391.001	-	
D	T	S	558453.001	-	
B	N	S	558464.001	-	
B	V	S	558465.001	551162	
B	E	S	558466.001	-	
B	T	S	558467.001	-	
K, W	T	W	558452.001	-	
S	T	S	558378 - 558378.001	ASK SAMOA 551050	
A	N	S	558460.001	-	
A	V	S	558461.001	-	
A	E	S	558462.001	-	
A	T	S	558459.001	-	
C	N	S	558472.001	551010, 551030	
C	N	S	558473.001	551020	

3			4		
PUSH ROD	SEALS	KIT CODE	PUSH ROD	SEALS	KIT CODE
S	N	558352.001	S	N	558398.001
S	V	558353.001	S	E	558379.001
S	T	558382.001	S	T	558474.001
Y	V	-	Y	V	558355.001
Y	T	558458.001	Y	T	-

NOTE: For Serial numbers prior to 329041/250 the replacement kit has to be ordered without .001 suffix.

6		CHECK VALVE BALL REPAIR KIT	
KIT CODE	NUMERICAL CODING	KIT CODE	NUMERICAL CODING
T	558363	T	551015, 551017, 551050, 551160, 551162, 551164
C	558365	C	551010, 551020
S	558367	S	-
N	558364	N	551030

7		DIAPHRAGMS	
DIAPHRAGMS	PUSH ROD	KIT CODE	NUMERICAL CODING
H	S	558368.001	551010, 551015, 551164
M	S	558369.001	-
N	S	558457.001	551030
T	S	558371.001	551017, 551020, 551050, 551160, 551162
T	Y	558395.001	-

MODEL EXAMPLE

directflo PATENTED WORLDWIDE

PUMP TYPE: **CE** **EHI** **0163**

PART No.: _____

YEAR: **II2 60** **II2/IC 95°C** **EX**

MARK. AIR / FLUID PRESSURE: _____

FLUID IN / OUT: _____

Part. No: 55XXXXX (numerical coding)
 Pump type: DF100XXXXXXX (alphanumeric coding)

REPAIR AND MAINTENANCE PROCEDURES

DIAPHRAGM REPLACEMENT

Before any intervention: DISCONNECT AIR SUPPLY OF THE PUMP. IT IS NOT NECESSARY TO REMOVE THE PUMP FROM THE FLUID LINE.

1. Close fluid valves.
2. Drain the fluid inside the pump. Anticipate a drainage of fluid from inside the pump.
3. Remove the directional valve while being careful not to damage the seals shown in the figure.
4. Remove the diaphragm cap.
NOTE: To tighten these screws you must use a torque wrench calibrated to (see torque table in this page).
5. Remove the cover by gently pulling back.
6. Remove the used diaphragm and place the new one in the proper position.
7. Mount the side covers again following the tightening sequence and torque (see torque table page 8, 10 and 12).

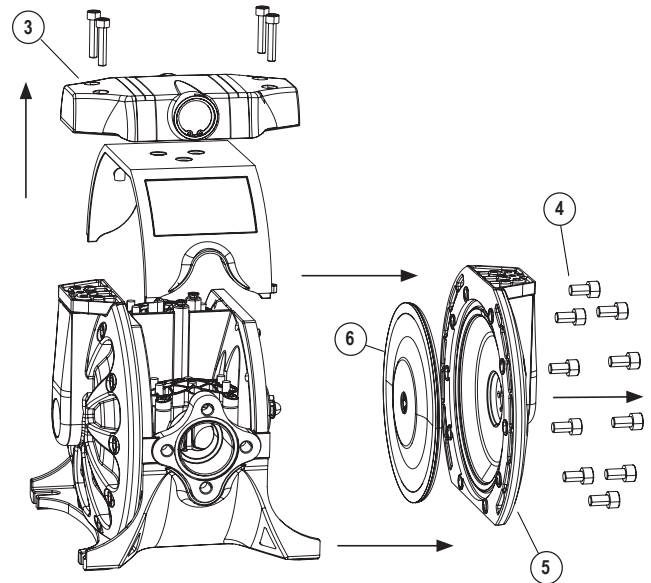

PUSHING ROD

Remove the side covers, following the procedure to "Replace diaphragms".

Once the shaft is visible, use the following procedures:

1. Remove the shaft from its housing by pulling it from one end.
The Teflon® sleeve is threaded into the body. To remove use snap ring pliers in the two holes indicated in the figure.
2. Once the cap has been removed, remove the quad ring inside the pump body.
3. Replace the kit following the correct order shown in the assembly drawing.
4. Mount the side covers again following the tightening sequence and torque (see torque table page 8, 10 and 12).

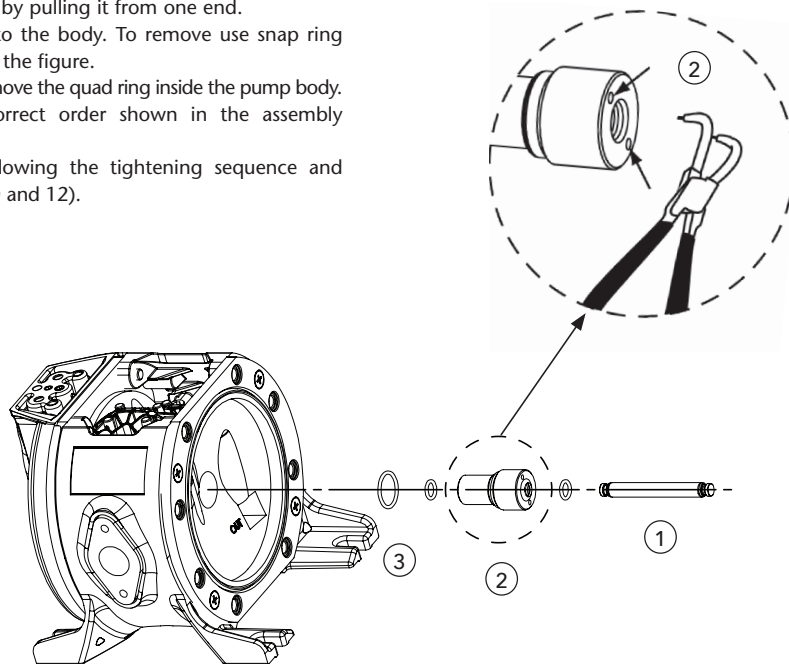

REPAIR AND MAINTENANCE PROCEDURES

BALL VALVES REPLACEMENT

1. Close fluid valves.
2. Drain the fluid from inside the pump. Anticipate a drainage of fluid from inside the pump.
3. Loosen the screws to remove the directional valve. Take special care with the seals.
4. Remove the valve cover by loosening the screws with an Allen wrench. Take note of the orientation of the cap, as it is critical to replace it correctly during reassembly.
5. Install a new set of valves according to these assembly drawings. Ensure that the ball guides are assembled as shown in the figure on the left, and tighten the screws with a maximum torque (see torque table page 8, 10 and 12).
6. Assemble the directional valve with being careful not to damage the O-rings and tighten the screws with a maximum torque of 44.25 lbf-in (5 N·m).

 **ATTENTION:** To avoid fluid restriction and leakages, follow the position of the ball checks guides in the figure above.

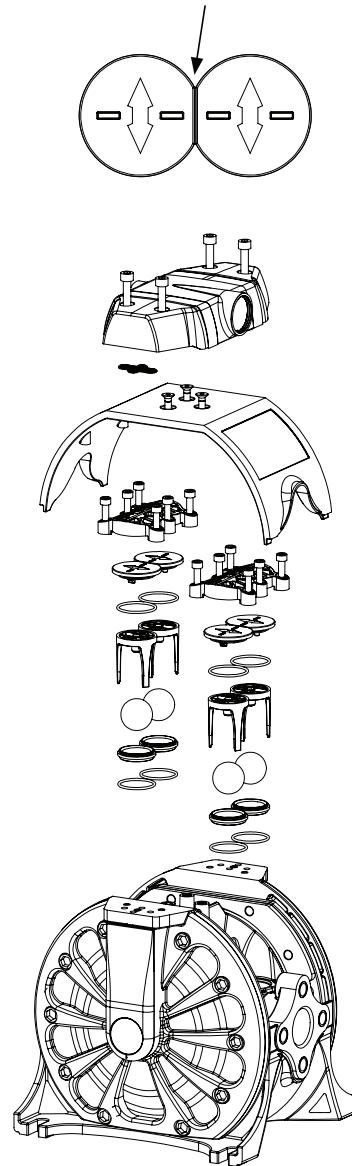

AIR SENSOR (ONLY FOR MODELS WITH DIRECTIONAL VALVE)

The air sensors are on the inside part of the diaphragm covers. To access them, follow the procedure for "Replacing diaphragms". Once removed the covers following procedure:

1. Remove the two screws that secure the air sensor to the top.
2. Remove all components of the sensor. Clean the area.
3. Introduce new components in the order shown.
4. Fit the cover on the pump and tighten the screws to the body of the pump. Maximum tightening torque (see torque of body pump parts).
5. Fit the remaining components in reverse order.

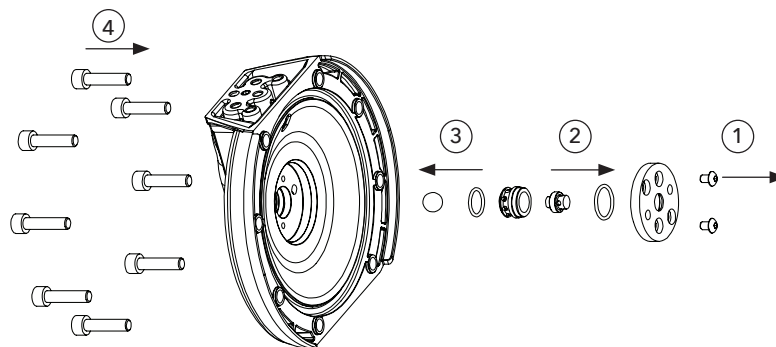

2017_12_04-13:30

DATOS TÉCNICOS

	DF30	DF50	DF100
RATIO	1:1	1:1	1:1
MÁXIMO CAUDAL SALIDA LIBRE	38 l/min (10 gal/min)	50 l/min (13.21 gal/min)	100 l/min (26.5 gal/min)
DESPLAZAMIENTO POR EMBOLADA	0,07 l (2.37 oz)	0,1 l (3.38 oz)	0,25 l (8.45 oz)
RANGO DE PRESIÓN	1,5 a 8 bar (22 a 115 psi)*	1,5 a 8 bar (22 a 115 psi)*	1,5 a 8 bar (22 a 115 psi)*
MAX. TAMAÑO DE PARTÍCULAS EN SUSPENSIÓN	3 mm (0.12 in)	3 mm (0.12 in)	4 mm (0.16 in)
ALTURA MÁXIMA DE SUCCIÓN	4 m (13.2 ft) seco 8 m (26.25 ft) húmedo	6 m (19.69 ft) seco 8 m (26.25 ft) húmedo	4,5 m (14.76 ft) seco 7 m (22.97 ft) húmedo
PESO	1,9 kg (4,19 lb)	3,5 kg (7.72 lb) Serie metálica con cuerpo de Aluminio 2,2 kg (4.85 lb) Serie plástica	7,2 kg (15.87 lb) Serie metálica cuerpo de Aluminio 11,2 kg (24.69 lb) Serie metálica cuerpo de Acero inoxidable 5,1 kg (11.24 lb) Serie no metálica
ENTRADA DE FLUIDO (CUERPO CON ENTRADA SIMPLE)	1/2" BSP - NPT (H) y brida	1/2" BSP - NPT (H) y brida	1" BSP - NPT (H) y brida
ENTRADA DE FLUIDO (CUERPO CON ENTRADA DOBLE)	2 x 3/8" BSP - NPT (H)	2 x 3/8" BSP - NPT (H)	-
SALIDA DE FLUIDO	1/2" BSP - NPT (H) y brida	1/2" BSP - NPT (H) y brida	1" BSP/NPT (H) y brida
ENTRADA DE AIRE	3/8" NPSM (H)	3/8" NPSM (H)	3/8" NPSM (H)
PARTES HÚMEDAS	Ver especificaciones de los modelos	Ver especificaciones de los modelos	Ver especificaciones de los modelos
NIVEL DE FLUIDO	80 dB	80 dB	80 dB
RANGO DE TEMPERATURAS DE TRABAJO	0 - 70 °C (32 - 158 °F)	0 - 70 °C (32 - 158 °F)	0 - 70 °C (32 - 158 °F)

* Membrana Hytrel® y Santoprene® 2,5 a 8 bar (36 a 115 psi).

(oz, ft, gal/min) todo en unidades americanas.

ADVERTENCIAS Y PREACUCIONES

En este documento usted encontrará advertencias y precauciones para la instalación, uso y mantenimiento de las bombas Directflo. A continuación le indicamos el significado de los símbolos y mencionamos unas advertencias generales que usted debe tener en cuenta.

 **ADVERTENCIA:** Este símbolo alerta de que si no se siguen las instrucciones indicadas se puede producir una situación de lesión grave o muerte.

ATENCIÓN: Este símbolo alerta de daños o destrucción del equipamiento si no se siguen las instrucciones.

 **ADVERTENCIA:** ¡LEA ATENTAMENTE EL MANUAL DE INSTRUCCIONES Y SUS ADVERTENCIAS ANTES DE EMPEZAR A OPERAR CON EL EQUIPO!

- Este equipo es únicamente para uso profesional.
- No altere la integridad del equipo. Use solamente componentes originales de Samoa Industrial, S.A.
- Los fluidos no adecuados para la bomba pueden causar daños a la unidad de la bomba e implicar riesgo de graves daños personales. Consulte siempre al distribuidor de Samoa Industrial, S.A. si se tiene alguna duda sobre la compatibilidad de los fluidos con los materiales de la bomba, incluyendo los elastómeros.
- Instale y use siempre la bomba según la normativa y la legislación sanitaria y de seguridad, tanto local como nacional.
- La bomba puede producir presiones de fluido iguales a la presión de alimentación del aire. No exceder la presión máxima permitida de alimentación de aire de 8 bar (115 psi). La presión hidráulica total (presión del sistema + presión diferencial) no deberá exceder nunca 8 bar (115 psi).
- No utilice nunca una bomba que tenga fugas o daños, esté corroída o de otra forma carezca de la capacidad para contener el fluido interno o la presión del aire.
- Comprobar con frecuencia que los tornillos de las tapas de la bomba están correctamente ajustados.
- No use modelos cuya parte húmeda esté basada en aluminio para productos de consumo humano, es posible que existan trazas de plomo.
- Peligro de explosión si se usa 1,1,1-tricloroetano, cloruro de metileno u otros disolventes de hidrocarburos halogenados en sistemas de fluido a presión que tengan componentes de aluminio humedecido. Podría causar graves daños materiales y personales incluso mortales.
- En el interior de la bomba, dos membranas separan el fluido bombeado de la alimentación de aire. Si se rompe una membrana, el fluido puede salir proyectado por el orificio de evacuación de aire.
- Cuando se manejen fluidos peligrosos, conecte siempre el orificio de evacuación de aire a un recipiente adecuado y situado en un lugar seguro. (Sistema de conexión opcional a petición del cliente. No se suministra con el equipo).
- Cuando la fuente de producto se encuentre a un nivel más elevado que la bomba (aspiración inundada), la impulsión deberá ser dirigida por un tubo a un nivel más alto que el producto para impedir los derrames causados por derivación sifónica.
- En las bombas que manejen fluidos peligrosos para las personas o el medio ambiente, se debe instalar algún tipo de recipiente o contenedor para recoger posibles fugas y evitar su derrame.
- Asegúrese de que el operario de este equipo esté formado en cuanto a la operación, limitaciones y uso de equipamiento de seguridad como gafas de seguridad u otro equipamiento requerido.

DESCRIPCIÓN

La bomba de membrana neumática es una bomba aspirante e impelente de desplazamiento positivo, accionada por aire y con dos cámaras de bombeo. Dos membranas ubicadas centralmente en las cámaras, separan el aire comprimido (lado seco) del fluido bombeado (lado húmedo). Las membranas están conectadas entre sí mediante un eje flotante cuyo funcionamiento permite la minimización del flujo pulsante. Una válvula (motor neumático) distribuye el aire de una cámara a la otra alternativamente, produciendo así un movimiento recíproco de las membranas.

En cada embolada, una de las membranas desplaza el fluido, mientras que la membrana opuesta aspira nuevo fluido al interior de la cámara de expansión. Cuatro válvulas de bola, dos en el lado de aspiración y dos en el lado de impulsión, controlan y dirigen el flujo del fluido.

MATERIALES	TEMPERATURA DE TRABAJO
PTFE	5 °C - 105 °C / 41 °F - 221 °F
NBR	10 °C - 80 °C / 50 °F - 176 °F
Acetal	10 °C - 90 °C / 50 °F - 194 °F
Hytrel®	10 °C - 90 °C / 50 °F - 194 °F
Santoprene®	-29 °C - 135 °C / -20 °F - 275 °F
Viton®	-10 °C - 120 °C / -4 °F - 248 °F
Polipropileno®	10 °C - 80 °C / 50 °F - 176 °F

INSTALACIÓN

RECOMENDACIONES PARA LA INSTALACIÓN

- Retire la bomba de la caja e instálela en el lugar elegido.
- Trate de reducir al mínimo la altura de aspiración.
- Recuerde disponer de espacio suficiente alrededor de la bomba para realizar las tareas de mantenimiento.
- Tenga siempre en cuenta usar correctamente la entrada y la salida de la bomba.
- En caso de fallo del diafragma el escape de aire de la bomba puede contener fluido.
- Cuando la bomba se instala en un lugar en el que pueda tener lugar un impacto en el medio ambiente, el escape debe orientarse hacia un lugar donde no haya impacto ambiental.
- Cuando instale la bomba en su lugar, utilice los soportes en la base y asegure la bomba fijándola con los tornillos de amarre.
- Apriete todos los tornillos de las tapas de la bomba.

Las bombas DF son muy flexibles y fáciles de instalar.

INUNDADA:

El sistema de bombeo se diseñó para presión positiva en la aspiración. Esta es la mejor forma de instalación cuando se necesite evacuar todo el líquido del bidón o depósito, o cuando se trabaje con fluidos viscosos. No recomendada para fluidos peligrosos.

ASPIRACIÓN:

La bomba DF está diseñada para generar vacío en la aspiración. Es posible evacuar todo el aire de una manguera o tubería sin dañar la bomba. La altura máxima de succión es de 6 m con la manguera de succión vacía y hasta 8 m con la manguera cebada (ver página 16).

SUMERGIDA:

Todas las bombas DF se pueden sumergir en los fluidos. Es importante que verifique que todos los componentes que están en contacto con el fluido son químicamente compatibles. En este caso, las salidas de aire y fluido deben ser conducidas al exterior mediante mangueras. (Sistema de conexión de aire opcional).

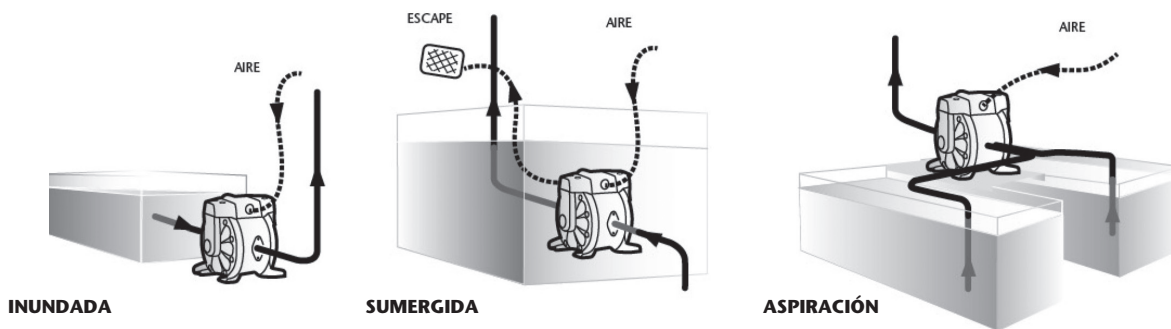

NOTA: Utilice un regulador de presión con filtro incorporado en la entrada de aire.

NOTA: La presión de alimentación de aire debe estar comprendida entre 1,5 bar (22 psi) y 8 bar (115 psi), Hytrel® y Santoprene® 2,5-8 bar (36-115 psi).

INSTALACIÓN RECOMENDADA

La siguiente figura muestra la configuración recomendada para la instalación de una bomba de diafragma.

Lea atentamente las advertencias y recomendaciones de la página anterior para realizar dicha instalación.

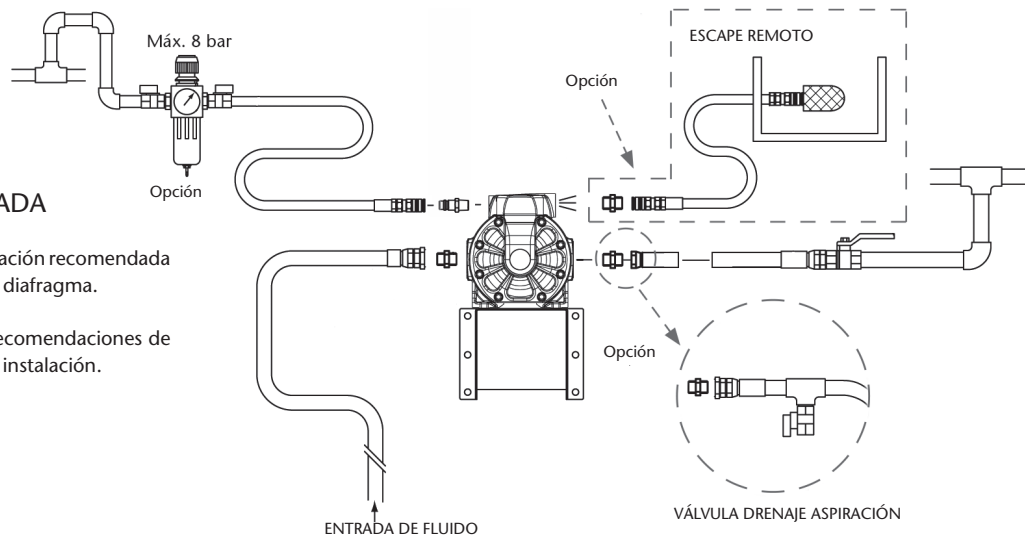

DISPOSICIÓN DEL ESCAPE EXTERIOR



ADVERTENCIA: El escape de la bomba debe estar orientado hacia un lugar seguro, alejado de la circulación humana, de animales y de alimentos.

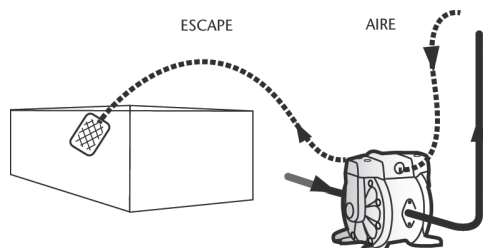

- Es necesario el kit opcional de salida conductiva.
- Retire el silenciador.
- Conecte una manguera con conexión a tierra al orificio de escape de la bomba e instale el silenciador en la punta de la manguera. Utilice una manguera del mismo diámetro que el orificio de escape. (Si la manguera mide más de 5 metros consulte al distribuidor o nuestra oficina regional).
- Disponga un foso, una caja de protección, etc. en el extremo de la manguera.

INSTALACIÓN

⚠ ADVERTENCIA

CONEXIÓN TOMA DE AIRE

Para que el suministro de aire sea suficiente para satisfacer la demanda de la bomba, el diámetro de la tubería debe ser igual al diámetro del orificio de suministro de la bomba. También elija equipos auxiliares y materiales con suficiente flujo de aire para el consumo de aire de la bomba.

También considere el uso y la estabilidad de la presión de aire. Además, el equipo periférico debe estar instalado lo más cerca posible de la unidad de la bomba. El uso de un acoplador para conectar cada manguera facilita la operación y las tareas de mantenimiento.

MODO DE OPERACIÓN

Esta bomba es auto-cebante. Para cebarla la primera vez, es conveniente conectar el aire a la bomba a la presión deseada con el regulador de presión, manteniendo la válvula de salida abierta.

Cuando el fluido empieza a salir, la bomba está cebada. Para su regulación mediante presión de fluido se debe alimentar con presión de aire comprendida entre 1,5 y 8 bar (22 - 115 psi), Hytrel® y Santoprene® 2,5 bar y 8 bar (36 y 115 psi). Ajuste la válvula de impulsión en el lado de descarga. Para la relación entre el flujo, la presión de suministro de aire y la presión de descarga, vea la curva de capacidad en la página 2.

PARADA DE LA BOMBA

- Cierre la válvula de entrada de fluido de la bomba.
- Abra la válvula de aire de la bomba, ponga en funcionamiento la bomba y descargue el fluido remanente.
- Cierre la válvula de impulsión en el lado de descarga, comience a abrir lentamente la válvula de drenaje y descargue el fluido bajo presión.
- Después de asegurarse de que la bomba se apagó y la presión se liberó, abra completamente el regulador y cierre la válvula de aire y la válvula de drenaje de la bomba.

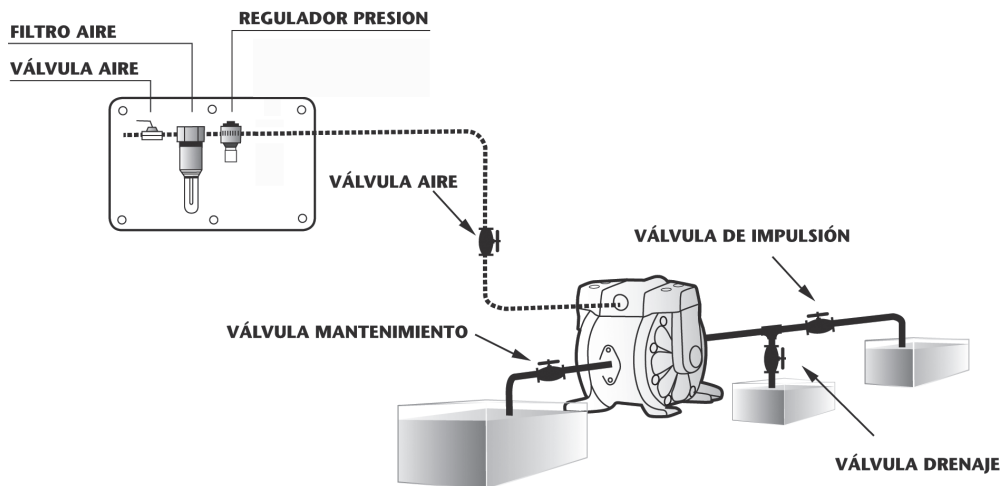

OPCIÓN CONEXIÓN A TIERRA

- Cuando instale la bomba, asegúrese de realizar la conexión a tierra en el lugar especificado.
- Conecte también conductores a tierra para los equipos auxiliares y las tuberías.
- Utilice un cable con conexión a tierra de por lo menos 2,0 mm² (12 gauge).
- Si la bomba que ha adquirido es válida para Atex, a este manual lo acompañará uno específico para Atex. Lea este manual antes de operar con la bomba.
- Si la bomba viene marcada con el símbolo , esta puede ser usada en atmósferas potencialmente explosivas. Debajo de este símbolo, en las placas de identificación de la bomba, vienen indicadas las zonas para las que el equipo está aprobado. Encontrará también la temperatura de superficie máxima permitida en la placa de su bomba.

ESTA ETIQUETA MUESTRA LA POSICIÓN DEL CABLE A TIERRA

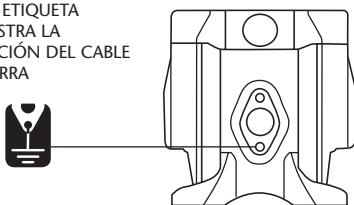

directflo ®		PATENTED WORLDWIDE	
PUMP TYPE:		CE	EAC
PART No.:			
YEAR:	SERIAL No.:	0163	
MAX. AIR / FLUID PRESSURE:		112 GD 11B/11C 95°C	
FLUID IN / OUT:		LOM 10ATEN0105X	

- ⚠ **ADVERTENCIA:** Asegúrese de conectar conductores a tierra para la bomba, tuberías y otros equipos conectados. Cuando la bomba opera sin conexión a tierra o con una conexión incorrecta, la fricción entre las piezas y la abrasión causada por algunos fluidos que fluyen dentro de la bomba pueden generar electricidad estática. Además, según el tipo de fluido a bombear y el ambiente de la instalación (como gases en el aire o el tipo de las instalaciones circundantes) la electricidad estática puede ser causa de incendio o choque eléctrico.

POSIBLES AVERÍAS Y SOLUCIONES

LA BOMBA NO FUNCIONA	
Causa	Medida a tomar
La válvula de impulsión en el lado de descarga no está abierta.	Abra la válvula de impulsión en el lado de descarga.
No llega aire.	Encienda el compresor y abra la válvula de aire y el regulador de aire.
La presión de suministro de aire es baja.	Revise el compresor y la configuración de la tubería de aire. Ajuste la presión de aire.
Fugas de aire en elementos de conexión.	Revise los elementos de conexión y el apriete de los tornillos.
La tubería de aire o el equipo auxiliar está obstruido con lodo.	Revise y limpie la tubería de aire.
El orificio de escape (silenciador) de la bomba está obstruido con lodo.	Revise y limpie el orificio de escape y el silenciador. Sustituya si es necesario.
La tubería de fluido está obstruida con lodo.	Revise y limpie la tubería de fluido.
La bomba está obstruida con lodo.	Desmonte, revise y limpie cuerpo de la bomba.

LA BOMBA FUNCIONA PERO EL FLUIDO NO SALE	
Causa	Medida a tomar
La válvula en el lado de succión no está abierta.	Abra la válvula en el lado de succión.
Demasiada altura de aspiración o altura de descarga.	Confirme la configuración de la tubería y reduzca la altura de la misma.
La tubería de fluido del lado de descarga (incluido el filtro) está obstruida con lodo.	Revise y limpie la tubería de fluido.
La bomba está obstruida con lodo.	Desmonte la bomba, revísela y límpiela.
Las bolas y el asiento de la bola están desgastados o dañados.	Revise y reemplace piezas defectuosas.

EL FLUJO ESTÁ DISMINUYENDO	
Causa	Medida a tomar
La presión de suministro de aire es baja.	Revise el compresor y la configuración de la tubería de aire. Ajuste la presión de aire.
La tubería de aire o el equipo periférico está obstruido con lodo.	Revise y limpie la tubería de aire.
La válvula de impulsión del lado de descarga no se abre normalmente.	Ajuste la válvula de impulsión del lado de descarga.
El aire se mezcla con el fluido.	Vuelva a llenar de fluido y revise la configuración de la tubería del lado de succión.
Se produce cavitación.	Ajuste la presión de suministro de aire y la presión de descarga y reduzca la altura de aspiración.
Se producen vibraciones.	Ajuste la presión de suministro de aire y la presión de descarga. Disminuya el flujo de la válvula de entrada para ajustar la presión y el volumen de fluido.
Formación de hielo en el escape de aire.	Elimine el hielo de la válvula de desvío de aire y revise y limpie el filtro de aire. Utilice una tubería en el escape de aire para que el hielo no se forme en el silenciador.
La tubería de fluido (incluido el filtro) está obstruida con lodo.	Revise y limpie la tubería de fluido y el colador.
El orificio de escape (silenciador) de la bomba está obstruido con lodo.	Revise y limpie el orificio de escape y el silenciador. Sustituya si es necesario.
La bomba está obstruida con lodo.	Desmonte, revise y limpie el cuerpo de la bomba.

FUGAS DE FLUIDO POR EL ORIFICO DE ESCAPE (SILENCIADOR)	
Causa	Medida a tomar
El diafragma está dañado.	Desmonte y revise la bomba y reemplace el diafragma.

EL FLUIDO SALE CON BURBUJAS DE AIRE	
Causa	Medida a tomar
Membrana dañada.	Sustituya la membrana.
Manguera de succión suelta o rota.	Apriete o sustituya.

RUIDO IRREGULAR	
Causa	Medida a tomar
La presión de suministro de aire es demasiado alta.	Ajuste la presión de suministro de aire.
La bomba está obstruida con partículas más grandes que el diámetro permitido.	Desmonte, revise y limpie el cuerpo de la bomba.
Los elementos de conexión y el soporte de la bomba tienen pérdidas.	Revise los elementos de conexión y apriete los tornillos.

NO ARRANCA Y QUEDA FUGANDO AIRE SIN HACER CICLOS	
Causa	Medida a tomar
Sensores de aire agarrotados.	Cambie sensor de aire.
Tambor de salida del pivote desgastado.	Cambie el tambor de salida.

FUGA AIRE ALIMENTADO A PRESIÓN ENTRE 3 Y 8 BAR	
Causa	Medida a tomar
Desgaste del pivote del motor de aire.	Cambie el motor de aire.

DESPIECE Y REPUESTOS DE LA BOMBA DF30

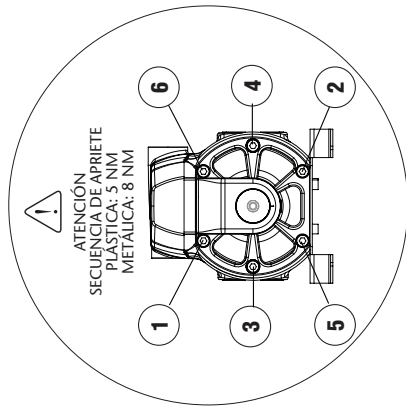

BOMBAS METÁLICAS O PLÁSTICAS CON TAPAS DE MEMBRANA DE ALUMINIO
Herramientas a utilizar para el mantenimiento

	TIPO TORNILLO	HERRAMIENTA REQUERIDA
DISTRIBUIDOR		
TAPAS MEMBRANA (Membrana y casquillo central)	Tornillo allen cabeza cilíndrica M6	Llave allen métrica: 5 mm Standard: 3/16"
TAPA VÁLVULAS (Válvula, asiento y juntas)	Tornillo allen cabeza cilíndrica M5	Llave allen métrica: 4 mm Standard: 5/32"

* Para el mantenimiento de los sensores de aire es necesario llave allen métrica 3 mm

BOMBAS NO-METÁLICAS

Herramientas a utilizar para el mantenimiento

	TIPO TORNILLO	HERRAMIENTA REQUERIDA
DISTRIBUIDOR		
TAPA VÁLVULAS (Válvula, asiento y juntas)	Tornillo allen cabeza cilíndrica M5	Llave allen métrica: 4 mm Standard: 5/32"
TAPAS MEMBRANA (Membrana y casquillo central)	Tornillo cabeza hexagonal M6	Llave de vaso métrica 10 mm Standard: N.A.

* Para el mantenimiento de los sensores de aire es necesario llave allen métrica 3 mm

COMPONENTES		
Pos.	Cód	Descripción Cant
1-21	755117	Tapa bomba aluminio 2
1-22	855685	Tapa bomba plástica 2
11	855420	Arandela cámara 4
15	855414	Soporte bomba metálica 1
16	855687	Soporte bomba plástica 1
17	855646	Embelecedor tapa bomba 2
18	940380	Tornillo tapa bomba aluminio 12
	940072	Tornillo tapa bomba plástica 12
19	855645	Carenas bomba simple 2
	855645+855670	Carenas bomba doble 1+1

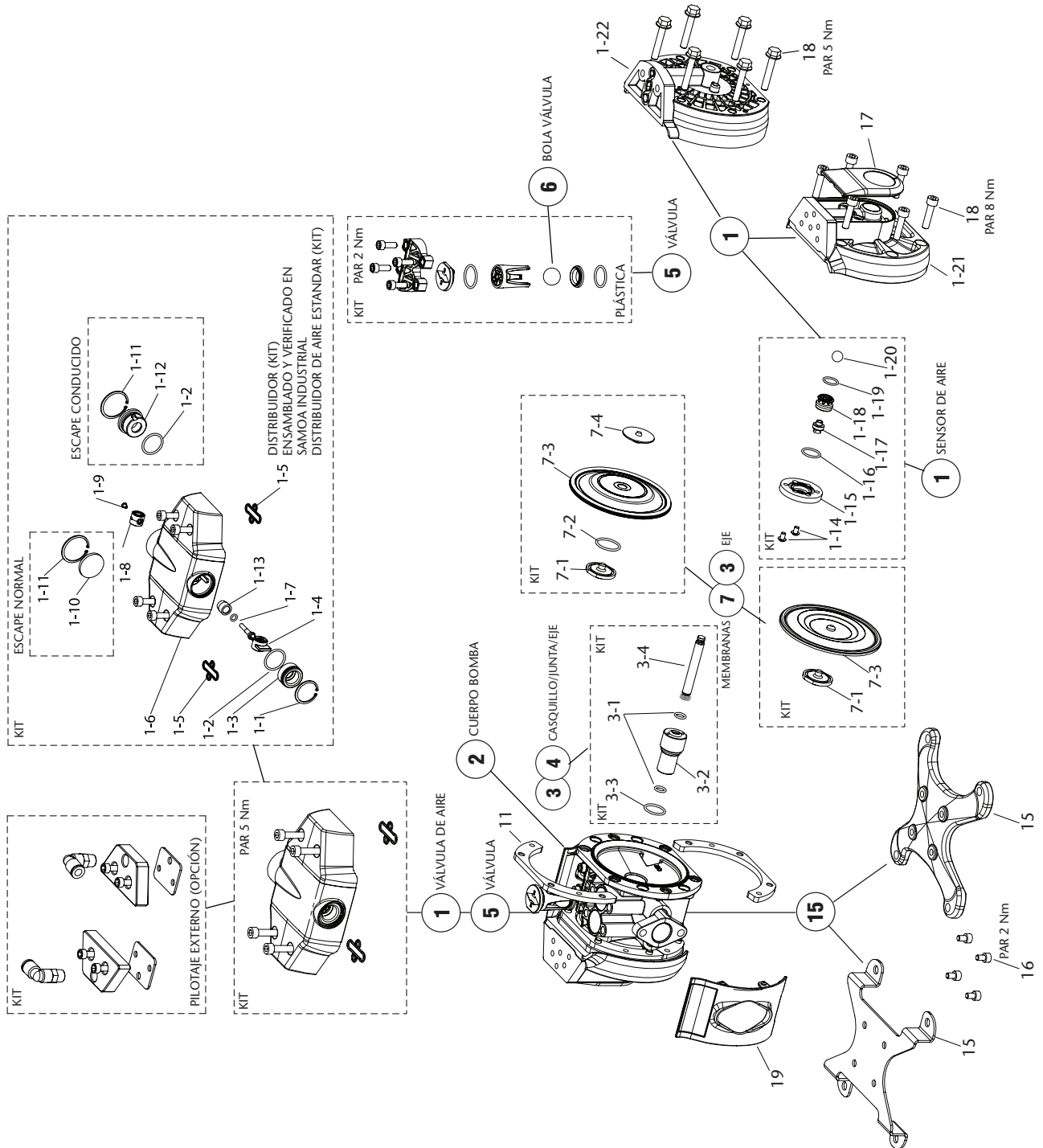

DF30	X	X	X	X	X	X	X	X	X	X	X	X	
	1	2	3	4	5	6	7	8	9				
DISTRIBUIDOR DE AIRE	CUERPO BOMBA	EJE	JUNTAS	ASIENTOS	BOLAS	MEMBRANAS	ROSCAS	OPCIONES					
A Aluminio P Polipropileno	P Polypropylene B Conductive PP D POM conductivo W PVDF K PVDF conductivo	S Acero inoxidable Y Hasteloy® C	N NBR V FKM E EPDM T PTFE	S Acero inoxidable W PVDF	T PTFE C POM S Acero inoxidable N NBR	H Hytrel® T PTFE M Santoprene® N NBR	B BSP N NPT F Brida	A Bomba estándar B Kit salida de aire roscada incluido E Control externo con válvula de solenoide (no incluida) F Silencioso de nariz incluido G Control externo con válvula de solenoide (no incluida) y sensor de final de Carrera inductivos NPN (incluidos) I Control externo con válvula de solenoide (no incluida) y sensor de final de Carrera inductivo ATEX –Namur- (incluidos) U Bomba para fluidos UV					

1	DISTRIBUIDOR DE AIRE	
	DISTRIBUIDOR DE AIRE	SENSOR DE AIRE
A	558300	558301
B	558343	-

2	CUERPO BOMBA			
	Cód. Kit			
	Simple	Doble	NPT	NPT
B	BSP	NPT	BSP	NPT
	855661	855661.300	-	-
D	855660	855660.300	-	-
P	855644	855644.300	855669	855669.300
W	855676	855676.300	-	-
K	855677	855677.300	-	-

2	4	5	KIT REPARACIÓN VÁLVULA	
CUERPO BOMBA	JUNTA	ASIENTO	CÓD. KIT	CODIFICACIÓN NUMÉRICA 55XXXX
P	V	S	558316.001	553010, 553020, 553124, 553160, 553164
P	E	S	558336.001	553161
P	T	S	558349.001	-
P	V	W	558318.001	-
P	T	W	558407.001	-
D	V	S	558417.001	-
D	E	S	558418.001	-
D	T	S	558419.001	-
B	V	S	558410.001	553162
B	E	S	558411.001	-
B	T	S	558412.001	-
K, W	T	W	558346.001	-

3	KIT REPARACIÓN EJE	
	EJE	CÓD. KIT
	S	558325.001
	S	558326.001
	S	558328.001
	S	558431.001
	Y	558427.001
	Y	558425.001

NOTA: Para modelos con número de serie anterior a 329041/250 los kits han de solicitarse sin el sufijo .001.

6	KIT REPARACIÓN BOLA VÁLVULA	
	Cód. kit	Codificación numérica 55xxxx
T	558319	553010, 553020, 553124, 553160, 553161, 553162, 553164
C	558321	-
S	558342	-
N	558320	-

7	MEMBRANAS	
	MEMBRANA	EJE
	H	S
	M	S
	N	S
	T	S
	T	Y

MODELO DE EJEMPLO

f.directflo PATENTED WORLDWIDE

PUMP TYPE: **CE** **EH**

PART No.: 0163

YEAR: **H2 6D**

MAX. AIR / FLUID PRESSURE: **H2/HIC 95°C**

FLUID IN / OUT: **UOM 10MT0105K**

Part. No: 55XXXX (numerical coding)
 Pump type: DF30XXXXXXX (alphanumeric coding)

DESPIECE Y REPUESTOS DE LA BOMBA DF50

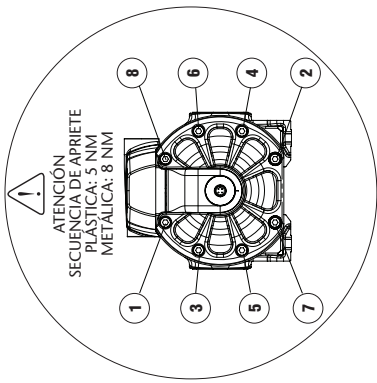

BOMBAS METÁLICAS O PLÁSTICAS CON TAPAS DE MEMBRANA DE ALUMINIO
Herramientas a utilizar para el mantenimiento

	TIPO TORNILLO	HERRAMIENTA REQUERIDA
DISTRIBUIDOR TAPAS MEMBRANA (Membrana y casquillo central)	Tornillo allen cabeza cilíndrica M6	Llave allen métrica: 5 mm Standard: 3/16"
TAPA VÁLVULAS (Válvula, asiento y juntas)	Tornillo allen cabeza cilíndrica M5	Llave allen métrica: 4 mm Standard: 5/32"

* Para el mantenimiento de los sensores de aire es necesario llave allen métrica 3 mm

BOMBAS NO-METÁLICAS

Herramientas a utilizar para el mantenimiento

	TIPO TORNILLO	HERRAMIENTA REQUERIDA
DISTRIBUIDOR	Tornillo allen cabeza cilíndrica M6	Llave allen métrica: 5 mm Standard: 3/16"
TAPA VÁLVULAS (Válvula, asiento y juntas)	Tornillo allen cabeza cilíndrica M5	Llave allen métrica: 4 mm Standard: 5/32"
TAPAS MEMBRANA (Membrana y casquillo central)	Tornillo cabeza hexagonal M6	Llave de vaso métrica 10 mm Standard: N.A.

* Para el mantenimiento de los sensores de aire es necesario llave allen métrica 3 mm

COMPONENTES		
Pos.	Cód	Descripción Cant
1-21	755106	Tapa bomba aluminio 2
1-22	894622	Tapa bomba plástica 2
10	940506	Tornillo fijación carena aluminio 8
11	855413	Arandela cámara 4
15	855687	Soporte bomba metálica 1
16	940319	Tornillo soporte bomba 4
17	855601	Embelecedor tapa bomba 2
18	940380	Tornillo tapa bomba aluminio 16
	940072+942156	Tornillo tapa bomba plástica 16+16
19	755108	Carenas bomba simple aluminio 2
	755108+755109	Carenas bomba doble aluminio 1+1
	855625	Carenas bomba simple plástica 2
	855625+855626	Carenas bomba doble plástica 1+1

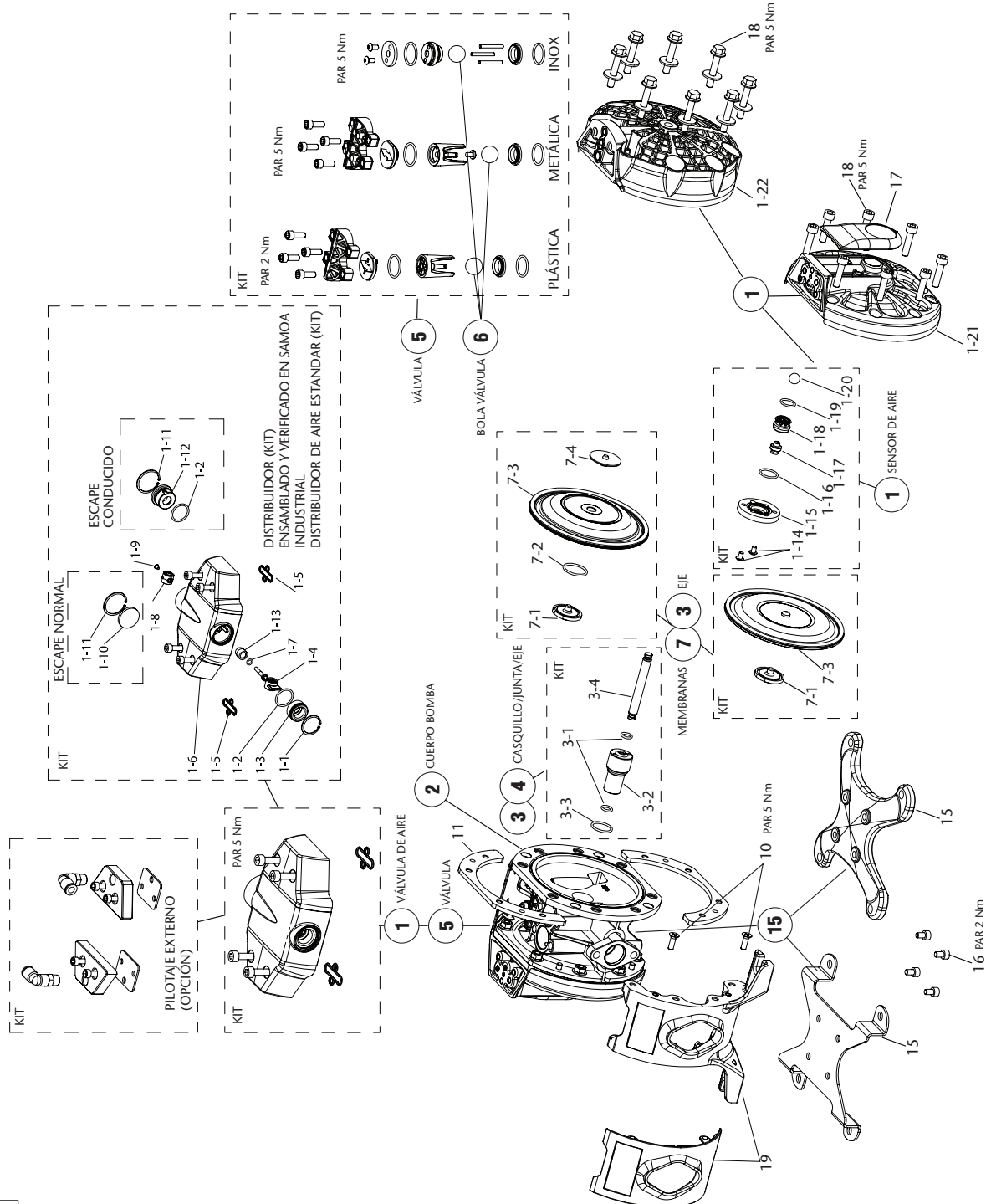

DF50																																																																																																																											
X X X X X X X X X X X X																																																																																																																											
1 2 3 4 5 6 7 8 9																																																																																																																											
DISTRIBUIDOR DE AIRE		CUERPO BOMBA		EJE		JUNTAS		ASIENTOS		BOLAS		MEMBRANAS		ROSCAS		OPCIONES																																																																																																											
A Aluminio P Polipropileno		A Aluminio S Acero inoxidable P Polypropylene B Conductive PP C POM D POM conductivo W PVDF K PVDF conductivo		S Acero inoxidable Y Hastelloy® C		N NBR V FKM E EPDM T PTFE		S Acero inoxidable W PVDF		T PTFE C POM S Acero inoxidable N NBR		H Hytre® T PTFE M Santoprene® N NBR		B BSP N NPT F Brida		A Bomba estándar B Kit salida de aire rosca incluida. E Control externo con válvula de solenoide (no incluida). F Silencioso de matriz incluido. G Control externo con válvula de solenoide (no incluida) y sensor de final de Carrera inductivos NPN (incluidos). I Control externo con válvula de solenoide (no incluida) y sensor de final de Carrera inductivo ATEX –Namur- (incluidos). U Bomba para fluidos UV.																																																																																																											
1 DISTRIBUIDOR DE AIRE <table border="1"> <tr> <th colspan="2">DISTRIBUIDOR DE AIRE</th> <th colspan="2">SENSOR DE AIRE</th> </tr> <tr> <td>A</td> <td>558300</td> <td></td> <td></td> </tr> <tr> <td>B</td> <td>558343</td> <td></td> <td>558301</td> </tr> </table>												DISTRIBUIDOR DE AIRE		SENSOR DE AIRE		A	558300			B	558343		558301																																																																																																				
DISTRIBUIDOR DE AIRE		SENSOR DE AIRE																																																																																																																									
A	558300																																																																																																																										
B	558343		558301																																																																																																																								
2 CUERPO BOMBA <table border="1"> <thead> <tr> <th colspan="2">Simple</th> <th colspan="2">Doble</th> </tr> <tr> <th>BSP</th> <th>NPT</th> <th>BSP</th> <th>NPT</th> </tr> </thead> <tbody> <tr> <td>A</td> <td>755104</td> <td>755104.300</td> <td>755105.300</td> </tr> <tr> <td>B</td> <td>855649</td> <td>855649.300</td> <td>855619.300</td> </tr> <tr> <td>C</td> <td>855618</td> <td>855618.300</td> <td>855628.300</td> </tr> <tr> <td>D</td> <td>855628</td> <td>855628.300</td> <td>855608.300</td> </tr> <tr> <td>P</td> <td>855607</td> <td>855607.300</td> <td>855050.300</td> </tr> <tr> <td>S</td> <td>855050</td> <td>855050.300</td> <td>855692.300</td> </tr> <tr> <td>W</td> <td>855692</td> <td>855692.300</td> <td>855697.300</td> </tr> <tr> <td>K</td> <td>855697</td> <td>855697.300</td> <td>-</td> </tr> </tbody> </table>												Simple		Doble		BSP	NPT	BSP	NPT	A	755104	755104.300	755105.300	B	855649	855649.300	855619.300	C	855618	855618.300	855628.300	D	855628	855628.300	855608.300	P	855607	855607.300	855050.300	S	855050	855050.300	855692.300	W	855692	855692.300	855697.300	K	855697	855697.300	-																																																																								
Simple		Doble																																																																																																																									
BSP	NPT	BSP	NPT																																																																																																																								
A	755104	755104.300	755105.300																																																																																																																								
B	855649	855649.300	855619.300																																																																																																																								
C	855618	855618.300	855628.300																																																																																																																								
D	855628	855628.300	855608.300																																																																																																																								
P	855607	855607.300	855050.300																																																																																																																								
S	855050	855050.300	855692.300																																																																																																																								
W	855692	855692.300	855697.300																																																																																																																								
K	855697	855697.300	-																																																																																																																								
3 DISTRIBUIDOR DE AIRE <table border="1"> <thead> <tr> <th colspan="2">DISTRIBUIDOR DE AIRE</th> <th colspan="2">ESCAPE CONDUCIDO</th> </tr> </thead> <tbody> <tr> <td>A</td> <td>558300</td> <td></td> <td></td> </tr> <tr> <td>B</td> <td>558343</td> <td></td> <td></td> </tr> </tbody> </table>												DISTRIBUIDOR DE AIRE		ESCAPE CONDUCIDO		A	558300			B	558343																																																																																																						
DISTRIBUIDOR DE AIRE		ESCAPE CONDUCIDO																																																																																																																									
A	558300																																																																																																																										
B	558343																																																																																																																										
4 KIT REPARACIÓN BOLA VÁLVULA <table border="1"> <thead> <tr> <th colspan="2">Codificación alfanumérica</th> <th colspan="2">Codificación numérica 55xxxx</th> </tr> <tr> <th>JUNTA</th> <th>Cód. kit</th> <th>EJE</th> <th>Cód. kit</th> </tr> </thead> <tbody> <tr> <td>T</td> <td>558319</td> <td>S</td> <td>558303.001</td> </tr> <tr> <td>C</td> <td>558321</td> <td>S</td> <td>558306.001</td> </tr> <tr> <td>S</td> <td>558342</td> <td>S</td> <td>558430.001</td> </tr> <tr> <td>N</td> <td>558320</td> <td>S</td> <td>558309.001</td> </tr> <tr> <td></td> <td></td> <td>Y</td> <td>558347.001</td> </tr> </tbody> </table>												Codificación alfanumérica		Codificación numérica 55xxxx		JUNTA	Cód. kit	EJE	Cód. kit	T	558319	S	558303.001	C	558321	S	558306.001	S	558342	S	558430.001	N	558320	S	558309.001			Y	558347.001																																																																																				
Codificación alfanumérica		Codificación numérica 55xxxx																																																																																																																									
JUNTA	Cód. kit	EJE	Cód. kit																																																																																																																								
T	558319	S	558303.001																																																																																																																								
C	558321	S	558306.001																																																																																																																								
S	558342	S	558430.001																																																																																																																								
N	558320	S	558309.001																																																																																																																								
		Y	558347.001																																																																																																																								
5 KIT REPARACIÓN VÁLVULA <table border="1"> <thead> <tr> <th colspan="2">Codificación alfanumérica</th> <th colspan="2">Codificación numérica 55xxxx</th> </tr> <tr> <th>JUNTA</th> <th>Cód. kit</th> <th>EJE</th> <th>Cód. kit</th> </tr> </thead> <tbody> <tr> <td>N</td> <td>558314.001</td> <td>S</td> <td>558314.001</td> </tr> <tr> <td>S</td> <td>558429.001</td> <td>S</td> <td>558429.001</td> </tr> <tr> <td>N</td> <td>558315.001</td> <td>S</td> <td>552010, 552016, 552024, 552030</td> </tr> <tr> <td>V</td> <td>558334.001</td> <td>S</td> <td>552014, 552016, 552024, 552026</td> </tr> <tr> <td>E</td> <td>558403.001</td> <td>S</td> <td>-</td> </tr> <tr> <td>T</td> <td>558403.001</td> <td>S</td> <td>-</td> </tr> <tr> <td>S</td> <td>558428.001</td> <td>S</td> <td>-</td> </tr> <tr> <td>V</td> <td>558408.001</td> <td>S</td> <td>-</td> </tr> <tr> <td>N</td> <td>558316.001</td> <td>S</td> <td>552013, 552015, 552023, 552025, 552124, 552160, 552164</td> </tr> <tr> <td>V</td> <td>558336.001</td> <td>S</td> <td>552161</td> </tr> <tr> <td>E</td> <td>558349.001</td> <td>S</td> <td>-</td> </tr> <tr> <td>T</td> <td>558318.001</td> <td>W</td> <td>-</td> </tr> <tr> <td>V</td> <td>558407.001</td> <td>W</td> <td>-</td> </tr> <tr> <td>T</td> <td>558417.001</td> <td>W</td> <td>552017, 552018</td> </tr> <tr> <td>V</td> <td>558418.001</td> <td>S</td> <td>-</td> </tr> <tr> <td>E</td> <td>558419.001</td> <td>S</td> <td>-</td> </tr> <tr> <td>S</td> <td>558410.001</td> <td>S</td> <td>552162</td> </tr> <tr> <td>V</td> <td>558411.001</td> <td>S</td> <td>-</td> </tr> <tr> <td>E</td> <td>558412.001</td> <td>S</td> <td>-</td> </tr> <tr> <td>T</td> <td>558346.001</td> <td>W</td> <td>-</td> </tr> <tr> <td>T</td> <td>558341 - 558341.001</td> <td>W</td> <td>552050 preguntat SAMOA</td> </tr> <tr> <td>S</td> <td>558421.001</td> <td>S</td> <td>-</td> </tr> <tr> <td>N</td> <td>558422.001</td> <td>S</td> <td>-</td> </tr> <tr> <td>V</td> <td>558423.001</td> <td>S</td> <td>-</td> </tr> <tr> <td>E</td> <td>558423.001</td> <td>S</td> <td>-</td> </tr> <tr> <td>A</td> <td>558424.001</td> <td>S</td> <td>-</td> </tr> </tbody> </table>												Codificación alfanumérica		Codificación numérica 55xxxx		JUNTA	Cód. kit	EJE	Cód. kit	N	558314.001	S	558314.001	S	558429.001	S	558429.001	N	558315.001	S	552010, 552016, 552024, 552030	V	558334.001	S	552014, 552016, 552024, 552026	E	558403.001	S	-	T	558403.001	S	-	S	558428.001	S	-	V	558408.001	S	-	N	558316.001	S	552013, 552015, 552023, 552025, 552124, 552160, 552164	V	558336.001	S	552161	E	558349.001	S	-	T	558318.001	W	-	V	558407.001	W	-	T	558417.001	W	552017, 552018	V	558418.001	S	-	E	558419.001	S	-	S	558410.001	S	552162	V	558411.001	S	-	E	558412.001	S	-	T	558346.001	W	-	T	558341 - 558341.001	W	552050 preguntat SAMOA	S	558421.001	S	-	N	558422.001	S	-	V	558423.001	S	-	E	558423.001	S	-	A	558424.001	S	-
Codificación alfanumérica		Codificación numérica 55xxxx																																																																																																																									
JUNTA	Cód. kit	EJE	Cód. kit																																																																																																																								
N	558314.001	S	558314.001																																																																																																																								
S	558429.001	S	558429.001																																																																																																																								
N	558315.001	S	552010, 552016, 552024, 552030																																																																																																																								
V	558334.001	S	552014, 552016, 552024, 552026																																																																																																																								
E	558403.001	S	-																																																																																																																								
T	558403.001	S	-																																																																																																																								
S	558428.001	S	-																																																																																																																								
V	558408.001	S	-																																																																																																																								
N	558316.001	S	552013, 552015, 552023, 552025, 552124, 552160, 552164																																																																																																																								
V	558336.001	S	552161																																																																																																																								
E	558349.001	S	-																																																																																																																								
T	558318.001	W	-																																																																																																																								
V	558407.001	W	-																																																																																																																								
T	558417.001	W	552017, 552018																																																																																																																								
V	558418.001	S	-																																																																																																																								
E	558419.001	S	-																																																																																																																								
S	558410.001	S	552162																																																																																																																								
V	558411.001	S	-																																																																																																																								
E	558412.001	S	-																																																																																																																								
T	558346.001	W	-																																																																																																																								
T	558341 - 558341.001	W	552050 preguntat SAMOA																																																																																																																								
S	558421.001	S	-																																																																																																																								
N	558422.001	S	-																																																																																																																								
V	558423.001	S	-																																																																																																																								
E	558423.001	S	-																																																																																																																								
A	558424.001	S	-																																																																																																																								
6 KIT REPARACIÓN BOLA VÁLVULA <table border="1"> <thead> <tr> <th colspan="2">Codificación alfanumérica</th> <th colspan="2">Codificación numérica 55xxxx</th> </tr> <tr> <th>JUNTA</th> <th>Cód. kit</th> <th>EJE</th> <th>Cód. kit</th> </tr> </thead> <tbody> <tr> <td>S</td> <td>558304.001</td> <td>S</td> <td>552010, 552030</td> </tr> <tr> <td>N</td> <td>558307.001</td> <td>S</td> <td>552015, 552016, 552017, 552018, 552025, 552026, 552124, 552160, 552162, 552164</td> </tr> <tr> <td>V</td> <td>558333.001</td> <td>S</td> <td>552161</td> </tr> <tr> <td>E</td> <td>558432.001</td> <td>S</td> <td>552013, 552014, 552023, 552024, 552050</td> </tr> <tr> <td>Y</td> <td>558312.001</td> <td>S</td> <td>-</td> </tr> <tr> <td>V</td> <td>558426.001</td> <td>S</td> <td>-</td> </tr> </tbody> </table>												Codificación alfanumérica		Codificación numérica 55xxxx		JUNTA	Cód. kit	EJE	Cód. kit	S	558304.001	S	552010, 552030	N	558307.001	S	552015, 552016, 552017, 552018, 552025, 552026, 552124, 552160, 552162, 552164	V	558333.001	S	552161	E	558432.001	S	552013, 552014, 552023, 552024, 552050	Y	558312.001	S	-	V	558426.001	S	-																																																																																
Codificación alfanumérica		Codificación numérica 55xxxx																																																																																																																									
JUNTA	Cód. kit	EJE	Cód. kit																																																																																																																								
S	558304.001	S	552010, 552030																																																																																																																								
N	558307.001	S	552015, 552016, 552017, 552018, 552025, 552026, 552124, 552160, 552162, 552164																																																																																																																								
V	558333.001	S	552161																																																																																																																								
E	558432.001	S	552013, 552014, 552023, 552024, 552050																																																																																																																								
Y	558312.001	S	-																																																																																																																								
V	558426.001	S	-																																																																																																																								
NOTA: Para modelos con número de serie anterior a 329041/250 los kits han de solicitarse sin el sufixo .001.																																																																																																																											
7 MEMBRANAS <table border="1"> <thead> <tr> <th colspan="2">Codificación alfanumérica</th> <th colspan="2">Codificación numérica 55xxxx</th> </tr> <tr> <th>MEMBRANA</th> <th>Cód. kit</th> <th>EJE</th> <th>Cód. kit</th> </tr> </thead> <tbody> <tr> <td>H</td> <td>558303.001</td> <td>S</td> <td>552010, 552011, 552016, 552018, 552021, 552025, 552026, 552124, 552164</td> </tr> <tr> <td>M</td> <td>558306.001</td> <td>S</td> <td>-</td> </tr> <tr> <td>N</td> <td>558430.001</td> <td>S</td> <td>552030</td> </tr> <tr> <td>T</td> <td>558309.001</td> <td>S</td> <td>552012, 552013, 552014, 552017, 552022, 552023, 552024, 552050, 552160, 552161, 552162</td> </tr> <tr> <td>T</td> <td>558347.001</td> <td>Y</td> <td>-</td> </tr> </tbody> </table>												Codificación alfanumérica		Codificación numérica 55xxxx		MEMBRANA	Cód. kit	EJE	Cód. kit	H	558303.001	S	552010, 552011, 552016, 552018, 552021, 552025, 552026, 552124, 552164	M	558306.001	S	-	N	558430.001	S	552030	T	558309.001	S	552012, 552013, 552014, 552017, 552022, 552023, 552024, 552050, 552160, 552161, 552162	T	558347.001	Y	-																																																																																				
Codificación alfanumérica		Codificación numérica 55xxxx																																																																																																																									
MEMBRANA	Cód. kit	EJE	Cód. kit																																																																																																																								
H	558303.001	S	552010, 552011, 552016, 552018, 552021, 552025, 552026, 552124, 552164																																																																																																																								
M	558306.001	S	-																																																																																																																								
N	558430.001	S	552030																																																																																																																								
T	558309.001	S	552012, 552013, 552014, 552017, 552022, 552023, 552024, 552050, 552160, 552161, 552162																																																																																																																								
T	558347.001	Y	-																																																																																																																								

MODELO DE EJEMPLO

f.directflo PATENTED WORLDWIDE

PUMP TYPE: **CE** **FH**

PART No.: **0163**

YEAR: **112 60**

MAX. AIR / FLUID PRESSURE: **118/118 95°C**

FLUID IN / OUT: **100M 100T00105K**

Part. No: 55XXXX (numerical coding)
 Pump type: DF50XXXXXXX (alphanumeric coding)

DESPIECE Y REPUESTOS DE LA BOMBA DF100

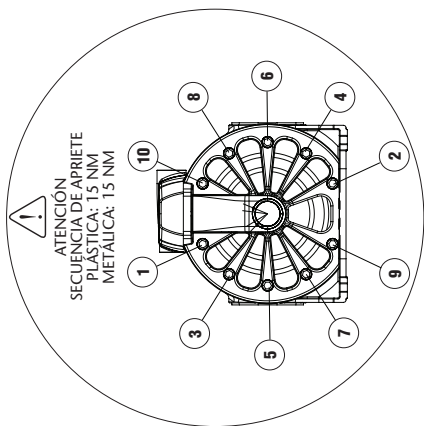

BOMBAS METÁLICAS O PLÁSTICAS CON TAPAS DE MEMBRANA DE ALUMINIO
Herramientas a utilizar para el mantenimiento

	TIPO TORNILLO	HERRAMIENTA REQUERIDA
DISTRIBUIDOR	Tornillo allen cabeza cilíndrica M6	Llave allen métrica: 5 mm Standard: 3/16"
TAPAS MEMBRANA (Membrana y casquillo central)	Tornillo allen cabeza cilíndrica M8	Llave allen métrica: 6 mm Standard: N.A.
TAPA VÁLVULAS (Válvula, asiento y juntas)	Tornillo allen cabeza cilíndrica M5	Llave allen métrica: 4 mm Standard: 5/32"

* Para el mantenimiento de los sensores de aire es necesario llave allen métrica 3 mm

BOMBAS NO-METÁLICAS

Herramientas a utilizar para el mantenimiento

	TIPO TORNILLO	HERRAMIENTA REQUERIDA
DISTRIBUIDOR	Tornillo allen cabeza cilíndrica M6	Llave allen métrica: 5 mm Standard: 3/16"
TAPA VÁLVULAS (Válvula, asiento y juntas)	Tornillo allen cabeza cilíndrica M5	Llave allen métrica: 4 mm Standard: 5/32"
TAPAS MEMBRANA (Membrana y casquillo central)	Tornillo cabeza hexagonal M8	Llave de vaso métrica 13 mm Standard: 1/2"

* Para el mantenimiento de los sensores de aire es necesario llave allen métrica 3 mm

COMPONENTES		
Pos.	Cód	Descripción Cant
1-21	755111	Tapa bomba aluminio 2
1-22	894621	Tapa bomba plástica 2
11	855416	Arandela cámara 4
15	755114	Soporte bomba metálica 1
	855637	Soporte bomba plástica 1
16	940914	Tornillo soporte bomba 7
17	855604	Embellecedor tapa bomba 2
18	940334	Tornillo tapa bomba aluminio 20
	940086+942158	Tornillo tapa bomba plástica 20+20
19	755113	Carenas bomba aluminio 1
	855636	Carenas bomba plástica 1

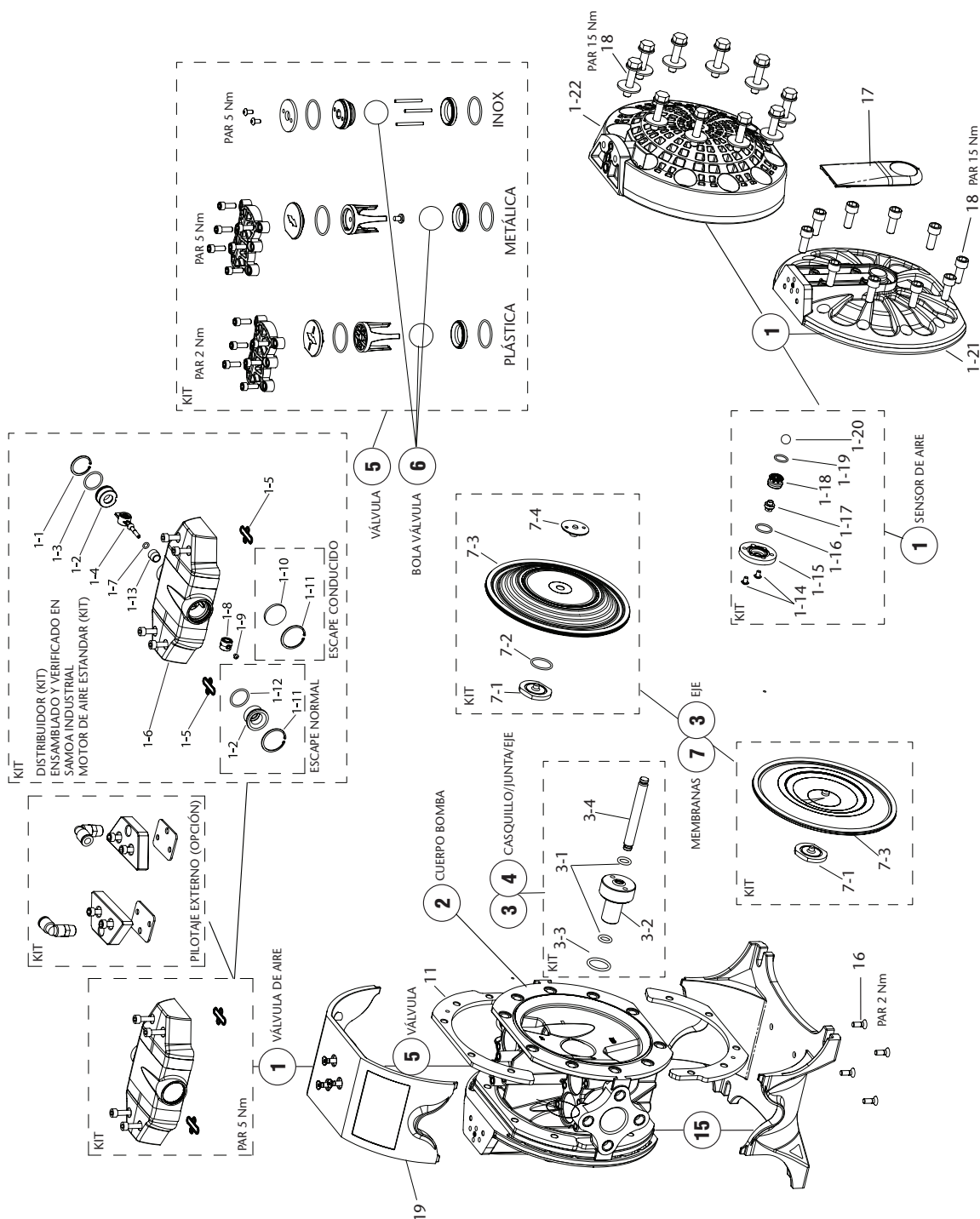

DF100	X	X	X	X	X	X	X	X	X	X	X	X	
	1	2	3	4	5	6	7	8	9				
DISTRIBUIDOR DE AIRE	CUERPO BOMBA	EJE	JUNTAS	ASIENTOS	BOLAS	MEMBRANAS	ROSCAS	OPCIONES					
A Aluminio P Polipropileno	A Aluminio S Acero inoxidable P Polypropylene B Conductive PP D POM, conductivo W PVDF K PVDF conductivo	S Acero inoxidable Y Hastelloy® C	N NBR V FKM E EPDM T PTFE	S Acero inoxidable W PVDF	T PTFE C POM S Acero inoxidable N NBR	H Hytrel® T PTFE M Santoprene® N NBR	B BSP N NPT F Brida	A Bomba estándar. B Kit salida de aire roscada incluido. D Sensor de ciclos. E Control externo con válvula de solenoide (no incluida). F Silencioso de naiz incluido. G Control externo con válvula de solenoide (no incluida) y sensor de final de Carrera inductivos NPN (incluidos). I Control externo con válvula de solenoide (no incluida) y sensor de final de Carrera inductivo ATEX -Namur- (incluidos). U Bomba para fluidos UV.					

1	DISTRIBUIDOR DE AIRE	
A	DISTRIBUIDOR DE AIRE	ESCAPE CONDUCTIVO
B	558350	-
	558395	-
2	CUERPO BOMBA	
A	BSP	NPT
B	755110	755110.300
D	855651	855651.300
P	855632	855632.300
S	855630	855630.300
W	855051	855051.300
K	894623	894623.300
	855698	855698.300

3	KIT REPARACIÓN EJE	
EJE	CÓD. KIT	CODIFICACIÓN NUMÉRICA 5SXXXX
S	Membranas Hytrel y Santoprene	Membranas Hytrel y Membranas PTFE y NBR
S	558352.001	558398.001
S	558353.001	558399.001
S	558382.001	558379.001
Y	558475.001	558474.001
Y	-	558355.001
Y	-	558458.001

NOTA: Para modelos con número de serie anterior a 329041/250 los kits han de solicitarse sin el sufijo .001.

2	KIT REPARACIÓN VÁLVULA	
CUERPO BOMBA	ASIENTO	CODIFICACIÓN NUMÉRICA 5SXXXX
P	N	-
P	V	551015, 551160, 551164
P	E	-
P	T	-
P	V	-
P	T	-
D	N	-
D	V	551017
D	S	-
D	T	-
B	N	-
B	V	551162
B	E	-
B	T	-
K, W	T	-
S	S	Preguntar SAMOA 551050
A	N	-
A	V	-
A	E	-
A	T	-
C	N	551010, 551030
C	S	558473.001

6	KIT REPARACIÓN BOLA VÁLVULA	
	Cód. kit	Codificación numérica 5Sxxxx
T	558363	551015, 551017, 551050, 551160, 551162, 551164
C	558365	551010, 551020
S	558367	-
N	558364	551030

7	MEMBRANAS	
MEMBRANA	EJE	Cód. kit
H	S	558368.001
M	S	558369.001
N	S	558457.001
T	S	558371.001
T	Y	558395.001

MODELO DE EJEMPLO

d.directflo PATENTED WORLDWIDE

PUMP TYPE: **CE EHI**

PART No.: **0163**

YEAR: **112 6D**

MAX. AIR / FLUID PRESSURE: **112/110**

FLUID IN. / OUT: **100/100**

Part. No: 55XXXX (numerical coding)
 Pump type: DF100XXXXXXX (alphanumeric coding)

CAMBIO DE MEMBRANAS

ANTES DE CADA INTERVENCIÓN: DESCONECTAR LA ALIMENTACIÓN DE AIRE DE LA BOMBA NO ES NECESARIO DESMONTAR LA BOMBA DE LA LÍNEA DE IMPULSIÓN DE FLUIDO.

1. Cierre las válvulas de fluido.
2. Drene el fluido del interior de la bomba. Prever un posible derramamiento de fluido del interior de la bomba.
3. Retire el distribuidor de aire con mucho cuidado de no dañar las juntas existentes entre el distribuidor y el cuerpo.
4. Desmonte la tapa de membrana.
5. Extraiga la tapa tirando suavemente hacia atrás.
6. Extraiga la membrana usada. Fíjese en la posición de la misma al extraerla. Coloque la nueva en la posición adecuada.
7. Monte las tapas laterales de nuevo siguiendo la secuencia de apriete y par (pág. 20, 22, 24).

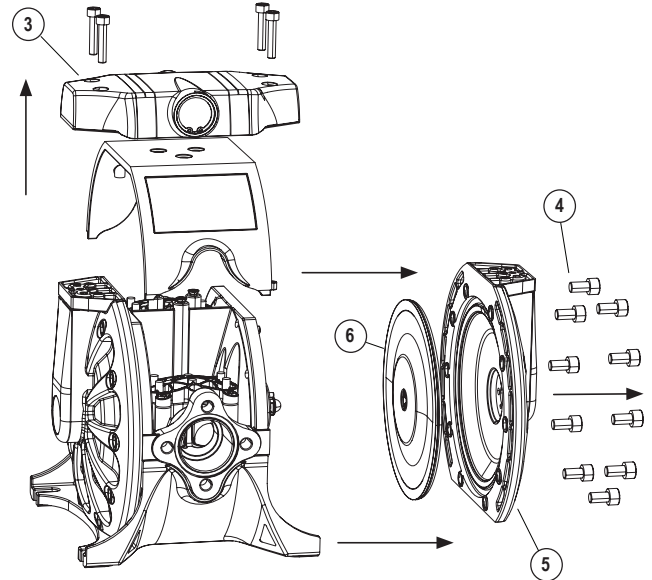

EJE CENTRAL

Desmonte las tapas laterales de ambos lados, siguiendo el procedimiento para "Cambio de membranas".

Una vez que se visualiza el eje, seguir los siguientes procedimientos:

1. Extraiga el eje de su alojamiento tirando de él por uno de sus extremos. El casquillo de Teflon® se encuentra roscado en el cuerpo. Para desmontar use un útil que se aloja en los dos taladros que se indican en la figura.
2. Una vez extraído el casquillo desmonte la tórica del interior del cuerpo de la bomba.
3. Monte el nuevo kit de eje central comprobando el correcto orden en el montaje de los componentes. Proceda al montaje de la bomba en orden inverso.
4. Monte las tapas laterales de nuevo siguiendo la secuencia de apriete y par (pág. 20, 22, 24).

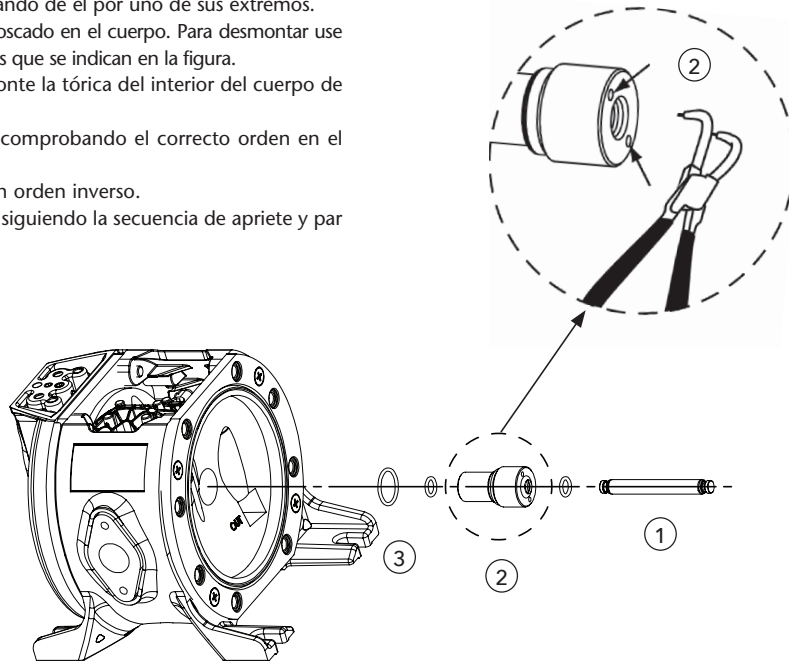

REPARACIÓN Y MANTENIMIENTO

CAMBIO DE LAS VÁLVULAS DE BOLA

1. Cierre las válvulas de fluido.
2. Drene el fluido del interior de la bomba. Prever un posible derramamiento de fluido del interior de la bomba.
3. Afloje los tornillos para desmontar el motor de aire. Preste especial cuidado a las juntas.
4. Desmonte la tapa de las válvulas aflojando los tornillos con una llave Allen. Recuerde la posición de estas tapas al retirarlas. Es imprescindible colocarlas en la misma posición.
5. Monte un nuevo conjunto de las bolas con las jaulas siguiendo el esquema de posicionamiento de las jaulas. Una colocación incorrecta producirá el funcionamiento incorrecto de la bomba.
6. Monte la tapa de válvulas comprobando el correcto montaje de las tóricas y en la misma posición que se retiraron. Vea en la página 20, 22 y 24 el par de apriete necesario y apriete los tornillos siguiendo una secuencia en cruz. Monte el motor de aire prestando atención de no dañar las juntas existentes entre distribuidor y cuerpo. Apriete los tornillos con un par de apriete máximo de 5 N-m.



ATENCIÓN: Para evitar restricción de fluido y fugas, respete la posición de las guías de las bolas que se muestra en la imagen.

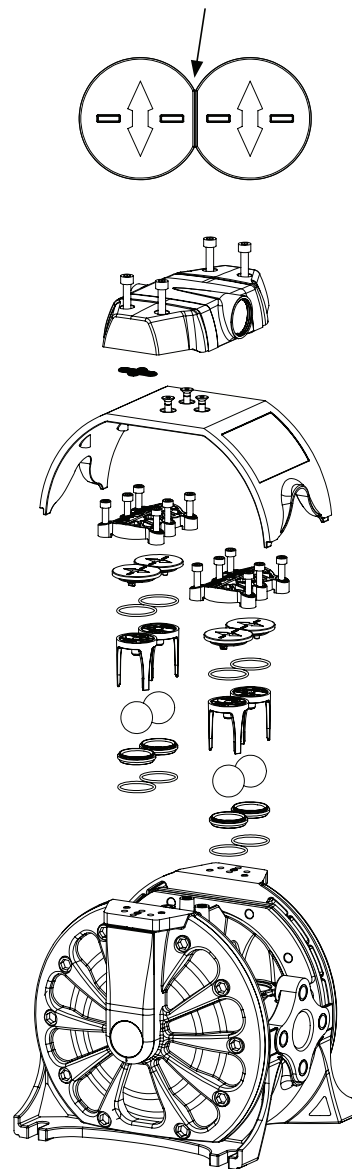

SENSOR DE AIRE (SOLO PARA BOMBAS CON MOTOR DE AIRE)

Los sensores de aire están alojados en las tapas. Para acceder a ellos seguir el procedimiento para "Cambio de membranas".

Una vez desmontadas las tapas seguir el procedimiento siguiente:

1. Desmonte los 2 tornillos que fijan el sensor de aire a la tapa.
2. Extraiga todos los componentes del sensor. Limpie el alojamiento de posibles suciedades.
3. Introduzca los nuevos componentes en el orden indicado.
4. Monte la tapa en la bomba y apriete los tornillos de fijación al cuerpo de la bomba. Vea par de apriete en la página 20, 22 y 24.
5. Monte el resto de componentes siguiendo el orden inverso.

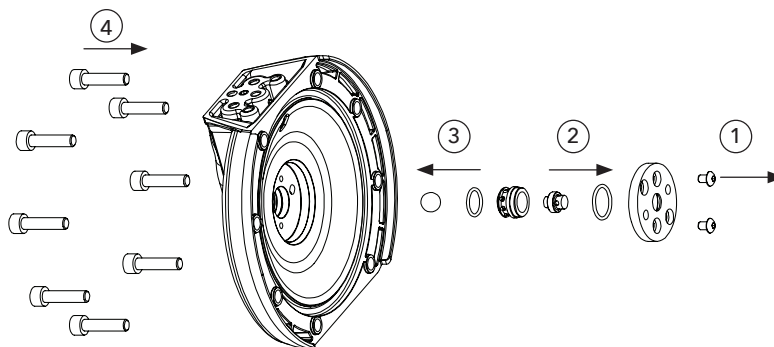

2017_12_04-13:30

EC CONFORMITY DECLARATION / DECLARATION CE DE CONFORMIDAD

EN

SAMOA INDUSTRIAL, S.A., Pol. Ind. Porceyo, I-14 · Camino del Fontán,
831 · 33392 - Gijón - Spain, declares that the product(s):
DP200 conform(s) with the EU Directive(s): **2006/42/EC**

ES

SAMOA INDUSTRIAL, S.A., Pol. Ind. Porceyo, I-14 · Camino del Fontán,
831 · 33392 - Gijón - España, declara que el(los) producto(s):
DP200 cumple(n) con la(s) Directiva(s) de la Unión Europea:
2006/42/CE

**For SAMOA INDUSTRIAL, S.A.
Por SAMOA INDUSTRIAL, S.A.**



Pedro E. Prallong Álvarez

Production Director
Director de Producción